



## SHEFFIELD CITY COUNCIL Individual Cabinet Member Decision

---

**Report of:** Executive Director, Place

---

**Date:** 9 June 2016

---

**Subject:** Tram/ Cycle infrastructure Review Study

---

**Author of Report:** Dick Skelton, 273407

---

**Summary:**

This report outlines a study into the Supertram infrastructure and cyclist safety. The study confirmed that there are problems for cyclists wherever there are tram systems and makes suggestions as to how cycle injury accidents may be reduced and some of the issues resolved.

---

**Reasons for Recommendations:**

Making improvements for cyclists along the route of the on-road tram system and collecting data on cycle incidents will, in the long term, reduce the number and severity of accidents, reduce the fear of accidents, encourage sustainable travel and contribute towards the creation of a more pleasant, cohesive environment.

**Recommendations:**

- 7.1 The Cabinet Member notes the number of injury accidents occurring to cyclists that are not recorded on official accident statistics.
  - 7.2 Subject to the level of available funding and any capital investments receiving the necessary endorsements through the Capital Gateway Approval Process, an on-going programme of improvements be undertaken as outlined in the body of this report.
  - 7.3 Opportunities to acquire further funding to address the issues outlined be pursued should they arise (e.g. if further cycle safety funding is made available from central government).
  - 7.4 The Tram/ Cycle Infrastructure Review Study be made available on the Council's website.
  - 7.5 The detail of the action plan is formulated in collaboration with Cycle Sheffield.
- 

**Background Papers:**

**Category of Report:** OPEN

---

## Statutory and Council Policy Checklist

<b>Financial Implications</b>
YES Cleared by: Damian Watkinson
<b>Legal Implications</b>
YES Cleared by: Richard Cannon
<b>Equality of Opportunity Implications</b>
YES Cleared by: Annemarie Johnston
<b>Tackling Health Inequalities Implications</b>
NO
<b>Human rights Implications</b>
NO:
<b>Environmental and Sustainability implications</b>
NO
<b>Economic impact</b>
NO
<b>Community safety implications</b>
NO
<b>Human resources implications</b>
NO
<b>Property implications</b>
NO
<b>Area(s) affected</b>
East, Central, Southeast
<b>Relevant Cabinet Portfolio Leader</b>
Councillor Mazher Iqbal
<b>Relevant Scrutiny Committee if decision called in</b>
Economic and Environmental Wellbeing
<b>Is the item a matter which is reserved for approval by the City Council?</b>
NO
<b>Press release</b>
YES

## TRAM/ CYCLE INFRASTRUCTURE REVIEW STUDY

### 1.0 SUMMARY

1.1 This report outlines a study into the Supertram infrastructure and cyclist safety. The study confirmed that there are problems for cyclists wherever there are tram systems and makes suggestions as to how cycle injury accidents may be reduced and some of the issues resolved.

### 2.0 WHAT DOES THIS MEAN FOR SHEFFIELD PEOPLE?

2.1 Introducing the types of measures outlined in the study should, over time, bring about a reduction in the number and severity of traffic accidents, thus helping to create *better health and wellbeing*. Together with an ongoing programme of publicity and education it should also contribute to the creation of a safer environment and a *thriving neighbourhoods and communities*. The inclusion of representatives from the Council's Cycle Forum in the preparation of the report and responses from individual cyclists about their experiences with the cycle/ tram interface, contributes to an *in touch organisation*.

### 3.0 OUTCOME AND SUSTAINABILITY

3.1 Implementing the study's recommendations, where this is possible, will contribute to the delivery of:

- The council's continuing *commitment to address traffic-related emissions* of the Corporate Plan;
- Policy W of the Sheffield City Region Transport Strategy 2011-2026 (*To encourage safer road use and reduce casualties on our roads*);
- The Council's Vision For Excellent Transport In Sheffield (*a better environment; a healthier population; a safer Sheffield*).

### 4.0 REPORT

4.1 The Council commissioned Amey to undertake a study into the tram/ cycle interface as there has been an increasing awareness, particularly in the last few years, that many more cycle injury accidents were occurring than those shown on official records.

4.2 The study also looked into problems around the world and found that the issues in Sheffield were similar to many other locations where a tram system has been implemented and information was available about tram infrastructure/ cycle accidents (UK 7 locations, Europe 24 locations, USA 7

locations, Canada 1 location, Australia 3 locations and New Zealand 1 location).

4.3 Looking at what others had implemented on other systems in terms of preventative measures helped to inform the study and broke down as follows in order of apparent increasing effectiveness:

- Signing – giving warnings
- Signing and lining – giving advice
- Removal of most other traffic
- Localised physical measures
- Segregation of cyclists from trams (and road traffic)

Examples from abroad and how similar arrangements might be implemented in Sheffield can be seen in Appendices 1, 4 and 5 of the attached study. Some typical costs are given in Appendix 6.

4.4 A particular issue raised by local cyclists was the use of red surfacing to guide vehicles away from the tram tracks. When used at the kerbside this can be confusing for cyclists as the red surfacing and associated white line can be misinterpreted as a cycle lane. This is a particular issue for new cyclists and those new to Sheffield (e.g. many university students each year).

Options for replacement of the nearside red surfacing are given in Appendix 3 of the study.

4.6 It should be noted that the study outlines that in some locations there will be little that can be done to improve the situation. Typical examples are Hillsborough Corner and the Glossop Rd / Upper Hanover St junctions where footway widths and pedestrian activity precluded almost any physical changes to the road and footway layouts

4.7 The study also considered the urban myth that other countries had solved the issue for cyclists by retrofitting 'rubber' inserts into the tracks. Unfortunately, while there have been trials, none have proved successful to date.

#### Collecting Information

4.8 As mentioned above local cyclists and organisations contributed to the study. In discussions it was agreed that it would be helpful if a comprehensive cycle accident report form for all cycle accidents, including tramway specific items, could be added to a public web site. This could then be publicised by SCC and cycle groups, so that more accurate information could be obtained in future.

4.9 CycleSheffield, embraced this suggestion in advance of this report and produced a tram (only) accident reporting website of its own. There have been around 300 reports by individuals who have had accidents in just over the last year, resulting from interaction between the tram rail and cycle wheels. Some of these incidents resulted in serious injury. It should be noted that this figure is unlikely to encompass all such incidents. However, as the study suggests, a more comprehensive accident reporting form for all cycle accidents in Sheffield should be introduced to address under-reporting by individuals and inconsistent collection of official accident data.

#### Action Plan

4.10 Officers from Traffic, Transportation and Parking Services (TTAPS) are currently working with Cycle Sheffield to develop our cycling ambitions. During 2016/17 we will be developing a new overall Transport Strategy for Sheffield which will consider how all modes of transport will support our ambitions for growth and ensure that communities are connected to jobs, training and services. However, in advance of the Transport Strategy being published we are working on a 'Cycle Transition Document', again in collaboration with Cycle Sheffield, to progress shorter term matters. It is recommended that the action plan arising from this study, which clearly sets out the way in which we will seek to address cyclist and tram incidents, should form part of this Transition Document.

4.11 Given the reduction in local government funding over recent years, one of the reasons for the report was to use it as a tool in bidding for any Government safety finance that may become available for cycling. However, there are some 'quick wins' and some preparatory design work that the Council should be able to fund, along with some more data collection to show a more realistic extent of the problem associated with tram tracks and at other locations for cyclists.

4.12 Quick Wins:

- Make known the online form to collect information on all cycle accidents to highlight the extent of the problem and demonstrate that the official figures give a very underestimated view of cycle only reported injury accidents. Without more accurate information there will continue to be 'no problem' and little prospect of additional Government funding. It should be noted that UK Trams have also expressed an interest in the development of the on line form for possible use across the UK tram networks. This online form is ready to be advertised widely ([www.sheffield.gov.uk/cycleincident](http://www.sheffield.gov.uk/cycleincident)).
- As the Streets Ahead maintenance programme progresses where there are significant areas of red surfacing at the kerbside, these should be replaced with hatched white lines, provided there are no road safety concerns at the particular location.
- Warning signs (Road Narrows with an explanatory plate below e.g. 'Tramstop') on the approach to on-carriageway stops.
- Positively signing 'local' alternative routes for cyclists.

- Posters in A&E, doctors' surgeries, etc, giving the link to the on-line form.
- Words of caution in relevant cycling publications (e.g. on the next edition of the Sheffield Cycle Map, etc). There is already a warning on the Council's cycling web pages.

#### 4.13 Longer Term:

- Infrastructure projects (e.g. providing cycle by passes around the back of tram stops where possible, routes avoiding the tram tracks altogether, etc).

#### 4.14 In terms of timescale and bearing in mind possible available funding, particularly in this financial year, a programme may look like:

##### Year 1(remainder of 2016/ 17)

- Set up the on line form (already complete), posters in A&E, etc.
- Ensure that words of caution are included on all relevant Council publications, including online.
- Start design of advance warning signs at tram stops, funding permitting.

##### Year 2: (2017/ 18)

- Complete tram stop advance warning signs.
- Design and start implementation local alternative routes.
- Start civils preliminary design work.

##### Year 3: (2018/ 19)

- Continue implementation of local alternative routes.
- Continue civils design work.

##### Later Years:

- Continue preparation/ improvement measures as appropriate.

#### Relevant Implications

4.15 No specific funding has been provided in this financial year to implement the study's recommendations. However, it may be possible to provide the limited funding necessary in this financial year from the STEP, LSTF3 (if this bid is successful) or other sources.

4.16 An Equality Impact Assessment concluded that overall reduced numbers of accidents involving cyclists should be positive for all those who cycle regardless of age, sex, race, faith, disability, sexuality, etc. There should be no negative equality impacts.

4.17 The Council has a legal duty when exercising the functions conferred on

them by the Road Traffic Regulation Act 1984 so as to secure the expeditious, convenient and safe movement of vehicular and other traffic (including cyclists). The measures proposed will be implemented by using powers available under the aforementioned act and in accordance with that duty.

## 5.0 ALTERNATIVE OPTIONS CONSIDERED

5.1 The study considered what has been implemented where there are other tram systems both in this country and further afield and has made suggestions and outlined potential solutions based on this.

## 6.0 REASONS FOR RECOMMENDATIONS

6.1 Making improvements for cyclists along the route of the on-road tram system and collecting data on cycle incidents will, in the long term, reduce the number and severity of accidents, reduce the fear of accidents, encourage sustainable travel and contribute towards the creation of a more pleasant, cohesive environment.

## 7.0 RECOMMENDATIONS

7.1 The Cabinet Member notes the number of injury accidents occurring to cyclists that are not recorded on official accident statistics.

7.2 Subject to the level of available funding and any capital investments receiving the necessary endorsements through the Capital Gateway Approval Process, an on-going programme of improvements be undertaken as outlined in the body of this report.

7.3 Opportunities to acquire further funding to address the issues outlined be pursued should they arise (e.g. if further cycle safety funding is made available from central government).

7.4 The Tram/ Cycle Infrastructure Review Study be made available on the Council's website.

7.5 The detail of the action plan is formulated in collaboration with Cycle Sheffield

Simon Green  
Executive Director, Place

9 June 2016



# Sheffield Streets Ahead

## Tram / Cycle Infrastructure Review Study

### Study Report

**Client: Sheffield City Council**

Document references:

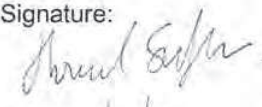
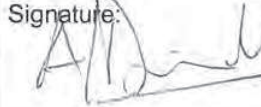
File: SHEFFIELD CITY COUNCIL - CYCLE TRAM STUDY REPORT - V1.0 - 08-09-15

Version: 1.0

Issued: 8<sup>th</sup> September 2015



Project Name:	Tram / Cycle Infrastructure Review Study
Project Number:	1737 – CO00208100 - 0024
Document / Report Title:	Study Report
Document / Report Number:	1737/CO00208100-0024/Report_v1-0

Issue Status/Amendment	Prepared	Reviewed	Approved
Issue 1.0	Name: Howard Saffer Signature:  Date: 8/9/15	Name: Keith Saunders Signature:  Date: 8/9/15	Name: Tony Driscoll Signature:  Date: 10/5/15

(Enter Details of Amendment)	Name: (print) Signature:  Date:	Name: (print) Signature:  Date:	Name: (print) Signature:  Date:
(Enter Details of Amendment)	Name: (print) Signature:  Date:	Name: (print) Signature:  Date:	Name: (print) Signature:  Date:
(Enter Details of Amendment)	Name: (print) Signature:  Date:	Name: (print) Signature:  Date:	Name: (print) Signature:  Date:

This document and its contents have been prepared and are intended solely for *Sheffield City Council's* information and use in relation to the *Tram / Cycle Infrastructure Review*.

Reproduction by any other party or in connection with any other matter is not permitted by Amey OW Ltd. Amey OW Ltd assumes no responsibility to any other party in respect of or arising out of or in connection with this document and/or its contents.

## Executive Summary

This project for Sheffield City Council was carried out to investigate various issues relating to problems for cyclists when crossing tram tracks. The intention has been to develop potential improvement schemes for different types of problem rail crossing arrangements, and to propose options for specific improvements at a number of known problem sites in Sheffield. These schemes would typically include highway civil engineering works as well as additional signing and lining to advise cyclists of problems with crossing the rails at specific locations and provide ways for cyclists to bypass the problem areas.

As part of this study, an initial investigation was carried out into problems on other tramway systems and methods used elsewhere to inform the design process. This investigation showed that similar problems are evident on many tramway systems worldwide and that there are some common methods of making improvements, but no complete solutions.

Problems identified by cyclists in Sheffield at various sites where accidents have occurred were assessed for common issues, and this has also informed the development of options in this study.

Consideration of other measures directly applicable to tram tracks and track grooves that could improve the safety for cyclists, without providing specific cycle facilities were also considered. Information about groove filler trials in other places were obtained, and investigations and testing of a potential treatment to the rail surface to provide some skid resistance are now in progress, in association with Sheffield University. Some further work, with a wider brief, investigating options to improve the safety of cyclists crossing tram tracks has also been initiated with Sheffield University.

Additionally, aspects of the dynamics of cycle/tram rail incidents were considered, which have led to the identification of issues which are potentially suitable for academic research and mathematical modelling of cycle tram rail interaction as cyclists cross the tracks. Some of this work could also lead to improved guidance for cyclists as to how best to cross tram rails safely.

The replacement of red surfaced areas alongside the tram tracks which were installed to deter motorised vehicles from driving on the rails was also considered. These areas are expensive to maintain and can be confusing for cyclists as they can be misinterpreted as cycle lanes. Various alternative arrangements were considered and proposals for replacement have been made.

## CONTENTS

### **Executive Summary**

## **1 Introduction**

### **1.1 Background**

### **1.2 Scope of study**

## **2 Investigations into Other Tramway Systems**

### **2.1 Methodology**

### **2.2 Problems identified**

### **2.3 Preventative measures**

- Segregation of cyclists from trams (and road traffic).
- Localised physical measures
- Removal of most other traffic
- Signing and lining – giving advice
- Signing – giving warnings

### **2.4 Use of similar measures in Sheffield**

## **3 Cycle / Tram Rail Incidents in Sheffield**

### **3.1 Data collection**

### **3.2 Data analysis and review**

### **3.3 Future collection of cycle incident data**

## **4 Red Surface Areas**

### **4.1 Background**

### **4.2 Replacement criteria**

### **4.3 Options**

### **4.4 Proposals**

## **5 Site Specific Cycle / Track Crossing Problems**

- 5.1 Sites to be investigated
- 5.2 Site classifications
- 5.3 Site investigations
- 5.4 Preliminary design concept options for problem sites
- 5.5 Desktop assessment of other problem sites

## **6 Consultation Process**

## **7 Strategic Issues**

- 7.1 Design of tram/cycle specific signs and road markings
- 7.2 Alternative cycle routes
- 7.3 Information and education for cyclists

## **8 Possible Track Safety Improvements for Cyclists**

- 8.1 Filling the gap and other methods
- 8.2 Inserts into grooved tramway rail
- 8.3 Inserts alongside standard rail
- 8.4 Other gap filling arrangements
- 8.5 Rail surface
- 8.6 Conclusion – rail issues

## **9 Cycle / track interfaces and advice for cyclists**

- 9.1 Theoretical matters
- 9.2 Traction Circle theory
- 9.3 The angle of crossing the tracks
- 9.4 Advice for cyclists

## **10 Conclusions**

## APPENDICES

1. Cycle Facilities and Traffic Management on other systems
2. Red Surface Areas – Options for Replacement
3. Red Surface Areas – Proposals
4. Preliminary Design Concept Options for Problem Sites
  - Shalesmoor – crossing full carriageway
  - Malin Bridge - leaving to R/H side
  - City Road/Park Grange Road – leaving to L/H side; leaving to R/H side
  - Tram Stop – Langsett Rd
  - Park Grange Croft - leaving to L/H side
  - Occupation Lane/Sheffield Road - leaving to L/H side
  - Hillsborough Corner – complex site
  - Glossop Road/Upper Hanover St - leaving to R/H side to central reserve
5. Desktop Assessment of other Problem Sites
  - Birley Lane tram stop
  - Birley Moor Rd / Birley Lane
  - Eckington Way
  - Fox Lane / White Lane
  - Gleadless Town End
  - Granville St
  - Manor Top
  - Middlewood Rd terminus
6. Typical Works Costs
7. Traction Circle Theory
8. Cycle / Rail Crossing Behaviour
9. Sheffield University – Student Project Brief
10. Links to Web Sites and Resources
11. Additional Work to Progress (non-site related)
12. Tram Rail – Groove Fillers

## 1 Introduction

### 1.1 Background

1.1.1 This study was commissioned by Sheffield City Council (SCC) in July 2014.

1.1.2 The original study brief and timescales for the project have been revised and extended as the study has progressed to accommodate issues identified early in the study and to allow more time for consultation, research work and the involvement of cycle groups in Sheffield.

### 1.2 Scope of study

1.2.1 The scope of the study as it has developed can now be summarised as follows:

- Investigation of cycle / tram rail crossing problems on other tramway systems in the UK and elsewhere, and how these problems have been alleviated or resolved on those systems.
- Analysis of cycle accident reports on the Sheffield Supertram network, and consideration of any identified problems in developing potential solutions for various sites in Sheffield.
- Assessment of red surfaced areas alongside the tram tracks with a view to replacement with an alternative treatment that is less confusing for cyclists and is easier to maintain.
- Analysis of cycle/tram rail crossing arrangements at various problem sites in Sheffield to categorise them into different types, potentially requiring different treatments.
- Detailed preliminary investigation of eight problem sites in Sheffield – from different problem categories (see Section 5.2) – and development of practicable alternatives (in concept) for these sites that could improve the safety for cyclists crossing the tracks.
- A brief consideration of how these and similar methods could be used at other identified sites in Sheffield.
- Consideration of possible physical improvements on and around the rails that could improve the safety of cyclists crossing the rails:
  - Review of trials of flangeway / groove filler and similar products that have taken place
  - Investigation into the possible treatment of tram rails with a non-skid treatment
- Consideration of cycle/tram rail crossing dynamics and cycle grip characteristics on various materials in relation to -
  - Improving our understanding of precisely how cycle accidents occur
  - Whether guidance for cyclists for crossing tram tracks safely could be improved
- Involvement of Sheffield University in the investigation of some of the physical aspects of cycle/rail accidents and measures that might improve these arrangements.

## 2 Investigations into Other Tramway Systems

### 2.1 Methodology

2.1.1 Before starting work on the investigation into improvements to cycle facilities on the Sheffield Supertram system, SCC requested that the following be investigated:

- What cycle / tram rail problems existed on other systems
- What measures and design features had been introduced on these systems to reduce or overcome these problems

2.1.2 The Study approach to this was to:

- Contact known representatives of on-street tramway organisations in the UK, and also Councils in towns and cities where there are tramways.
- Carry out research on the Internet into other systems (including cycle forums, Councils, tramway operators, media articles, reports by consultants and others, manufacturers products, etc.) and then seek to contact relevant persons and organisations where matters of interest have been identified.

### 2.2 Problems identified

2.2.1 During this research it was found that problems associated with cyclists sliding on tram tracks and/or getting a wheel stuck in the groove were very common on tramways worldwide, with examples being identified in the UK, Europe, USA, Canada, Australia and New Zealand.

Table 1 shows some locations where cycle /tram rail problems have been reported:

COUNTRY	TOWN / CITY	COUNTRY	TOWN / CITY
<b>UK</b>	Blackpool	<b>Holland</b>	Amsterdam
	Croydon		
	Edinburgh	<b>Italy</b>	Milan
	Manchester		Venice - Translohr (guide rail)
	Nottingham (NET)	<b>Spain</b>	Barcelona
	Sheffield		Vitoria-Gasteiz - near Bilbao
Wolverhampton (Midlands)			
<b>Ireland</b>	Dublin (LUAS)	<b>Belgium</b>	Brussels
<b>France</b>	Avrille		Ghent
	Besancon		Antwerp
	Le Mans		
	Rouen	<b>USA</b>	Arlington
	Strasbourg		Atlanta
Toulouse	Boston		
	New Orleans		
<b>Germany</b>	Berlin		Portland
	Bremen (legal case)		Seattle (legal cases)
	Halle (Saale) / MZ (near Leipzig)		Tucson, Arizona
	Karlsruhe		
	Kassel	<b>Canada</b>	Toronto
<b>Austria</b>	Vienna	<b>Australia</b>	Sydney
			Melbourne
<b>Switzerland</b>	Geneva		Ballarat
	Zurich		
	Basel	<b>New Zealand</b>	Christchurch

Table 1 – Locations where cycle/tram rail problems have been reported

2.2.2 It is thought likely that most other on-street tramway systems would suffer some similar problems, even if this information is not easily accessible to the public or on the Internet.

2.2.3 It was found that, apart from primary accidents caused due to cyclists falling off their bicycles, secondary accidents were also common, and it was these that were most likely to lead to serious and fatal injuries.



Figure 1 – cycle wheel stuck in rail

2.2.4 In addition to crossing the tracks at shallow angles, other problems included kerbside tram stops, the location of tram switches and crossings, poor road surface conditions, other street ironwork and intimidation of cyclists by other drivers, particularly where cyclists are constrained by the position of the rails.

2.2.5 Some other problems (such as 'dooring', where cyclists are hit by opening car doors) are less likely to be relevant for Sheffield, as this mainly relates to cycle lanes which are situated between parking areas and the tram tracks, a design arrangement that is not used in Sheffield.

2.2.6 In many locations where problems have arisen, there are on-line forums and local user groups of cyclists trying to persuade their local Council and tramway operator to take action to resolve the problems. These were found in Europe, USA and Australia.

2.2.7 In various places (USA and Europe) there have been legal actions taken by cyclists against tramway operators for poor design standards affecting cycle safety relating to deaths and serious injuries. In the few cases where there is more information available, the outcome appears to have been in favour of the tramway operator. At the time of this report it is understood that a legal action may be progressed in Edinburgh. These actions clearly indicate the scale of cyclists' concern about these issues and the severity of accidents on some systems.

2.2.8 From articles and web forums it would appear that many cyclists worldwide believe that track / cycle crossing problems in Europe (e.g. in Holland) have already been fully resolved. However, it is clear from the information that was obtained that, even with various measures and design arrangements being introduced to reduce these issues, some problems still exist on many European tramway systems. Cyclists and tram operators in these places generally seem to be aware of this and, even in Holland, there is advice provided to cyclists about how to cross the tracks safely.

2.2.9 It is often reported that these problems can be resolved by installing rubber or similar inserts in the rail groove and there are numerous requests for tramway operators and Councils to do this. Although there is at least one product that might be used effectively in some situations, there do not appear to be any which are specifically designed for use at typical tramway operational frequencies on-street, running in and alongside live traffic (rather than for level crossing type arrangements). In addition, the type of concrete track slab construction system that was installed in Sheffield poses particular difficulties for the installation of these alternative



systems unless the tram track formation is fully re-constructed. A review of some of these systems and products is included in Section 8.

2.2.10 Of particular note is a very comprehensive system for recording cycle / tram track accident data for a tramway (modern streetcar) system in Tucson, Arizona, which was structured in a very similar way (using a GoogleMaps Fusion database) to the data that was collected by SCC and SYPTTE in Sheffield. The similarity of accidents to those in Sheffield was indicative of how the dynamics of these incidents occurring must be very similar on different systems worldwide. A link to this data set (including incident maps) is provided in Appendix 10.

2.2.11 The widespread nature of most of these problems worldwide is indicative that they are unlikely to be specific to any particular type of rail or track installation method in the highway. However this is not something that could easily be assessed from the information available.

## 2.3 Preventative measures

2.3.1 A range of design methodologies, arrangements and preventative measures have been implemented on systems worldwide. Although it would appear that these have not previously been classified in any particular strategic hierarchy, the measures could be considered in a number of categories and rated in (increasing) order of the effectiveness that has been indicated by designers and operators of other systems:

- **Signing – giving warnings**  
Caution and warning signs of various types were commonly used on many systems, mainly where no other specific advice could easily be given.
- **Signing and lining – giving advice**  
Signs and lines which provide advice to cyclists as to which position to take on the carriageway to cross the tracks or to use cycle facilities bypassing the problem area were commonly used and look as if they would be helpful at problematic locations.
- **Removal of most other traffic**  
Even if cyclists are riding amongst trams, and alongside or crossing tram tracks, this seems to be safer if there are no other motorised vehicles to intimidate cyclists, and cyclists can then more easily choose when to cross the tracks.
- **Localised physical measures**  
Segregation at specific locations to cross tram tracks, or to bypass them (e.g. behind kerbside tram stops), was considered to be effective and helpful as long as the diversion away from the cyclist's desire line along the route was not too great.
- **Segregation of cyclists from trams (and road traffic)**  
In general, the greater the degree of segregation, the more effective the measures, so that cycle tracks away from the tram alignment were preferable to those segregated by a hard separation strip (and also to a simple cycle lane arrangement on-street). An extension of this principle was the provision of alternative parallel routes for cyclists away from the tram routes but serving the same destinations.

- 2.3.2 Examples of various types of all these facilities are shown in Appendix 1.
- 2.3.3 Information concerning an alternative approach to make it safer for cyclists to cross the tracks by effectively removing the gap alongside the rail (the flangeway or groove) at problem locations is discussed in Section 8 below.

## 2.4 Use of similar measures in Sheffield

- 2.4.1 The measures indicated above and illustrated in Appendix 1 have been helpful in considering how various measures might be implemented in Sheffield. However space limitations in the highway, narrow footways near the tramway and significant levels of pedestrian activity in various locations mean that opportunities that some other tramways (especially in Holland, USA and Canada) have been able to utilise are not readily available on most of the Supertram network. This is something that was known from the outset, but became clearer as designers tried to adapt these techniques to problem sites in Sheffield.

## 3 Cycle / Tram Rail Incidents in Sheffield

### 3.1 Data Collection

- 3.1.1 Adequate data for cycle incidents in relation to crossing tram tracks in Sheffield is almost non-existent. Standard road accident data (Stats19) recorded and collected by the Police rarely includes cyclist-only accidents as these single person ('vehicle') accidents tend not to be reported to the Police, even if the cyclist needs to attend hospital. It is also understood that even some accidents reported to the Police may not be included in Stats 19 records.
- 3.1.2 Other data for these accidents is also not readily available. Hospital casualty data may record a cycling accident as a cause but would not normally identify whether the accident occurred over tram tracks.
- 3.1.3 Generally, the only accident data available is when cyclists report incidents to SCC, SYPTE or Supertram. However these records are few and, in Sheffield (just as for most other tramways in the UK, and elsewhere), it is generally considered that under-reporting of these types of incidents could be significant. The under-reporting of cycle/tram rail accidents is referred to in several other sources.
- 3.1.4 At the start of this study, SCC requested information through cycle groups in Sheffield about specific incidents that cyclists had personally experienced on the Supertram system. The 88 reports collected span more than 15 years and, whilst these are of interest, there is no suggestion that this is a complete data set or that it is statistically significant.

### 3.2 Data Analysis and Review

- 3.2.1 The incident data collected from cyclists by SCC was recorded in a Google Fusion database, which gives positional information that can be viewed on a Google map in aerial or map view mode (see Figure 2 below).

3.2.2 Unfortunately the quality of data about incidents and their location was variable. This meant that it was even more difficult to identify trends of incidents in relation to either their type or their location.

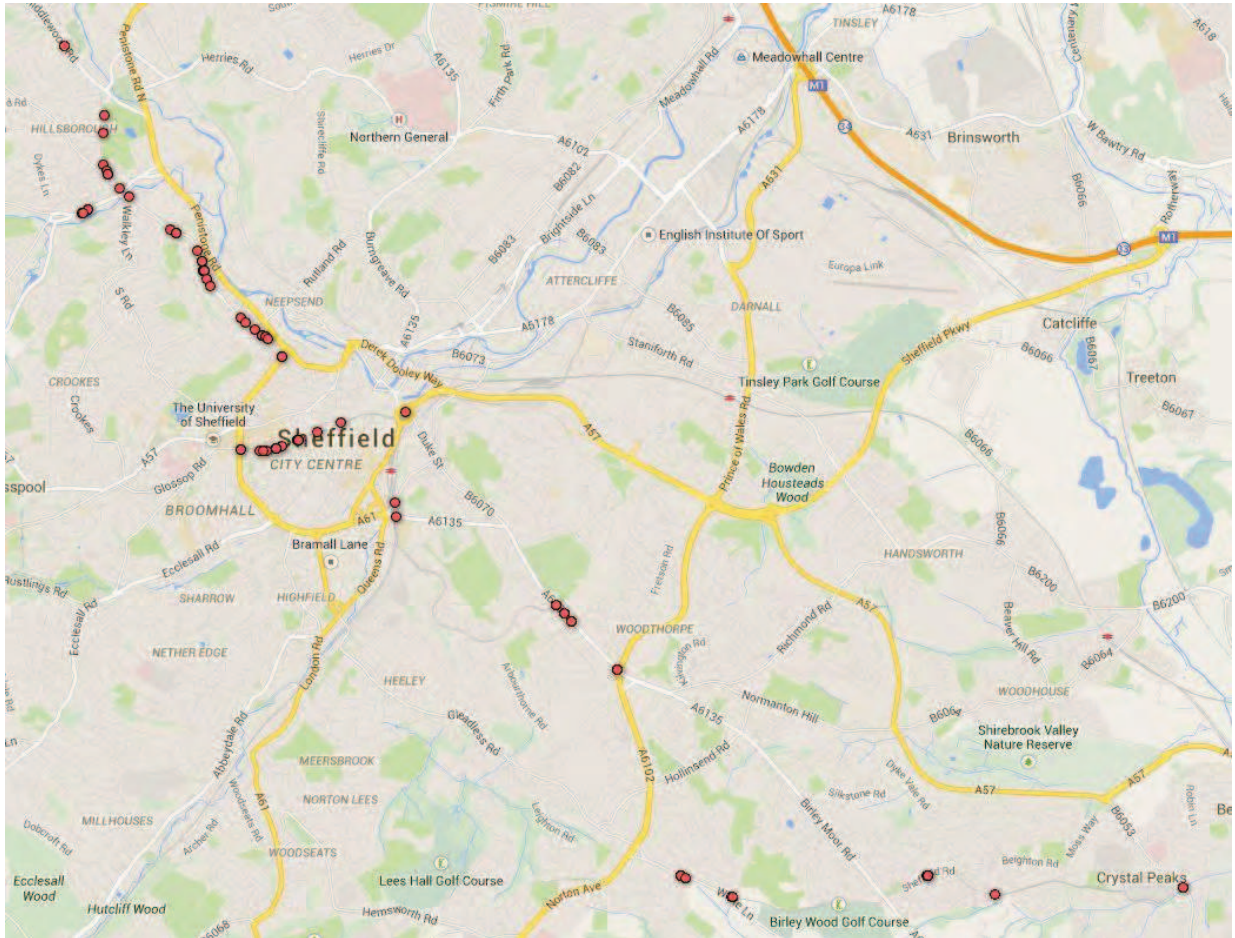


Figure 2 – Map of reported tram / cycle incidents in Sheffield

3.2.3 This data was reviewed and discussed at a meeting with representatives from cycle groups in Sheffield, SCC, SYPT and Supertram.

3.2.4 Whilst most incidents seemed to occur in wet conditions (or on wet rails), as anticipated, a number also occurred in (what were recorded as) dry conditions.

3.2.5 Only two locations were identified as having a cluster of incidents in this data set, on West St near Mappin St (an area of intense student activity); and near tram stops, particularly on Langsett Rd near Primrose Hill. This tram stop was therefore looked at as an example of a tram stop problem in the preliminary design concept assessment work in this study. West St near Mappin St is a straight section of track which does not seem to have the same problems as most other sites in this study but may be a site that is worth future investigation.

### **3.3 Future collection of cycle incident data**

3.3.1 It was noted that data analysis of cycle accidents in general and in relation to tram tracks was very difficult due to the lack of accurate and timely data from cyclists and other sources.

3.3.2 In discussions with SCC and cycle group representatives, it was agreed that it would be helpful if a comprehensive cycle accident report form for all cycle accidents, including tramway specific items, could be added to a public web site. This could then be publicised by SCC and cycle groups, so that more accurate information could be obtained in future.

3.3.3 This is an action that SCC will seek to address in conjunction with cycle groups in Sheffield.

## **4 Red Surfaced Areas**

### **4.1 Background**

4.1.1 One aspect of this study was to consider the replacement of red surfaced areas bounded by a white line alongside the tram tracks, which were originally installed to guide four wheeled vehicles away from driving on the rails to try to prevent them from losing control. Installation of these areas followed a number of serious 'loss of control' vehicle incidents on tram tracks during the early days of Supertram operation, one of which resulted in a major legal case.

4.1.2 These areas are expensive to maintain and may be confusing for cyclists as they can be misinterpreted as cycle lanes, especially for new cyclists and those who are new to Sheffield. This is clear from correspondence received by SCC.

4.1.3 The first task was to investigate some of these areas for condition and driver compliance. Generally driver compliance was good even though the condition of the red surfacing and the lining was generally poor, and in the case of lining, sometimes almost non-existent.

### **4.2 Replacement criteria**

4.2.1 The criteria for replacement were discussed at length with SCC and SYPT. The replacement criteria which were agreed are:

- Remove (or not replace) red textured surfacing (due to replacement and maintenance costs)
- Should deter drivers of motorised vehicles from driving on the tram tracks
- Should change the perception of cyclists of this area (i.e. even though it should not be seen as a reduced width cycle lane, it should still, preferably, allow cyclists to access and use these areas)

### 4.3 Options

- 4.3.1 Various options were explored, including through discussions with manufacturers and suppliers. Some materials and options were ruled out as they are only suitable for factory and low traffic areas, and would not comply with highway legislation and guidance.
- 4.3.2 The following were considered as potentially suitable options –
- Remove all existing treatments – no replacement
  - Other textured surfacing
  - Hatched (white lining) areas
  - Simple line markings (without hatching)
  - Alternative edge line markings
    - Rainline
    - Ribline
    - Vibraline
    - Weatherline
    - Weatherline Plus
    - Line marking with textured surfacing in narrow strip
- 4.3.3 It was confirmed with suppliers that all of these materials have sufficient skid resistance to be capable of being safely ridden over, and would not present any additional hazards for cyclists.
- 4.3.4 Images of these materials are shown in Appendix 2.

### 4.4 Proposals

- 4.4.1 After initial discussions with SCC, SYPTE and representatives of cycle groups, it was decided to progress with the simplest option of hatched markings with white hazard warning lines (generally 4m line, 2m gap). This had been used successfully in Nottingham in a similar way and met most of the criteria in Section 4.2.1 above. It is also relatively cheap and easy to maintain.
- 4.4.2 However, during later discussions between various parties, including SYPTE and Amey's Road Safety Audit representatives, it was realised that the additional requirement to still allow use by cyclists creates some conflicts in the design of these currently red surfaced areas. If the area actually excludes all road users, including cyclists, then no further requirements should be necessary on the approach to kerb-side tram stops. However, if it is considered that cyclists will continue to ride in these areas, then some additional warning of the imminence of approaching a tram stop might be necessary for cyclists to help them take the best position for crossing the rails on the approach.
- 4.4.3 It was eventually decided that no additional measures on the road surface should be provided on the approach to tram stops. However, in site specific locations, particularly where visibility is poor, signs could be provided warning of approaching a tram stop. This could be one of

several possible warning sign and plate variants shown in Appendix 1 which will probably require Department for Transport (DfT) sign authorisation.

- 4.4.4 In replacing the existing red areas with hatching and warning lines, checks may be carried out at the design stage to ensure that all of the current area is still required. It is considered that in some places small reductions in the size of these areas may be possible without affecting their purpose (for example on the start and end of some sections).
- 4.4.5 It is anticipated that any replacement of the existing red areas with alternative markings will also be subject to a Road Safety Audit (RSA). The RSA process might be specific just to this replacement work, or where carried out under the Sheffield Streets Ahead Highway Zone works, it could be part of the RSA for those works.
- 4.4.6 The brief for the replacement of these areas is shown in Appendix 3

## **5 Site Specific Cycle / Track Crossing Problems**

### **5.1 Sites to be investigated**

- 5.1.1 As part of the brief for this work, 13 sites were included where specific problems for cyclists had been noted in the past as causing problems in crossing the rails or where cycle/tram rail incidents had occurred.
- 5.1.2 It was agreed to review these arrangements, split them into categories based on the type of tram crossing arrangement, and to investigate in more detail at least one of each type. This was with a view to proposing some new facilities that could assist cyclists in crossing the tracks more safely, or bypass the crossing location altogether.
- 5.1.3 Other sites on the list would then be looked at briefly to see how the arrangements devised for these initial sites might be adopted for other locations.

### **5.2 Site Classifications**

- 5.2.1 In analysing the sites, the following issues were considered:
- Whether the tram leaves the carriageway towards the left or the right
  - Whether the tram crossed the full carriageway or only part of it
  - If the crossing was at a road junction, the type and complexity of the junction
  - Whether the site had a single location where cyclists needed to cross the tracks or several places around the junction (for example at Manor Top)
- 5.2.2 In the above descriptions and in the following list, the designation of leaving the road carriageway to the left hand (L/H) side or to the right hand (R/H) side is in relation to the tram driver's view of the road, and whether the tram is travelling inbound (I/B) or outbound (O/B) to Sheffield City Centre.

5.2.3 The list of sites divided into six categories is as follows:-

**Trams entering/leaving the carriageway**

- Middlewood Road - leaving to R/H side (O/B)
- Malin Bridge - leaving to R/H side (O/B)
- Park Grange Croft - leaving to L/H side (I/B)
- Birley Lane tram stop – leaving to L/H side (I/B)

**Trams fully crossing a carriageway**

- Shalesmoor – on approach to signalled roundabout
- Eckington Way - on approach/exit to Rbt

**Tram tracks crossing at a T-junction**

- Fox Lane/White Lane - leaving to L/H side (O/B)
- Occupation Lane/Sheffield Road - leaving to L/H side (O/B)

**Trams turning around a corner at a road junction (90° left/right turns)**

- City Road/Park Grange Road
- Glossop Road/Upper Hanover Street - leaving to R/H side to central reserve area (O/B)

**Complex junctions – with Multiple Crossing Points**

- Manor Top
- Hillsborough Corner
- Gleadless Townend (Ridgeway Road/White Lane/Gleadless Road)
- Granville Street and Shrewsbury Road junctions
- Birley Moor Rd / Birley Lane – and the neighbouring junction

**Tram stops**

- On street - build-outs from kerb  
(for example – Langsett Rd near Primrose Hill)

## 5.3 Site Investigations

5.3.1 The sites chosen for more a more detailed investigation were:

- Shalesmoor
- Malin Bridge
- City Road/Park Grange Road
- Tram Stop (at Langsett Rd near Primrose Hill)
- Park Grange Croft
- Occupation Lane/Sheffield Road
- Hillsborough Corner
- Glossop Road/Upper Hanover Street

- 5.3.2 The initial investigations carried out at each site were as follows:
- Check of site using Internet tools (e.g. Google Maps and Streetview).
  - Check of existing drawings for signals, signing, etc.
  - Site visit to check characteristics and problems of site.
  - During site visit, if possible, observe cyclist routes through the junction or crossing, riding paths and cyclist behaviour. Wherever possible, observations of cyclists were recorded on video.
  - Review options for existing cycle routing through the track arrangement, and the advantages and problems of different crossing points of the tracks.
- 5.3.3 Following the initial investigations, works that could be carried out at these locations to help cyclists cross the tracks more safely, or bypass them, were identified.
- 5.3.4 In investigating options for improvements, the following hierarchy of different methods that have been used on other tramway system was used, in order of precedence:
- Segregation from tramway or diversion onto other roads bypassing track crossing points
  - Local physical measures to assist crossing the tracks (combined with signing and lining)
  - Traffic signing and lining
- 5.3.5 The study team at Amey included staff with previous knowledge and experience of tramway design matters, highway design, and the design of traffic signals and traffic signs and lines. In order to maximise the credibility of the proposals, we also involved an engineer who is an experienced cyclist but who had no previous highway or traffic design experience, and a Road Safety Auditor to carry out reviews of the proposed arrangements.
- 5.3.6 Details of the investigations including comments by the study team are included in Appendix 4. However it should be noted that formal RSA stage 1 reviews have **not** been carried out as part of this study.
- 5.3.7 Specific recommendations about which schemes would be most worthwhile progressing have **not** been made in this report. It is considered that this will be a matter for discussion between Sheffield City Council, SYPTE, Supertram and cycle groups as to which proposals are likely to be most helpful and useful to cyclists. It will also depend on the availability of funding and other considerations.
- 5.3.8 An initial cost estimate has been made for each of these schemes, and these are included in Appendix 4. Typical costs of some standard items are also provided in Appendix 6. However these costs are very preliminary and would be subject to re-assessment following detailed design. These costs also **exclude** costs for traffic management during works, preliminaries on site and any utility works that may be necessary as it has not been possible to identify these costs at this stage.



- 5.3.9 During the course of these investigations it became very clear that there would be further possibilities to make improvements if more land was available around sites, footway and pedestrian refuge islands were wider and if these areas were not already widely used by pedestrians, in some cases in large numbers. Typical examples are the Hillsborough Corner and Glossop Rd / Upper Hanover St junctions where footway widths and pedestrian activity precluded almost any physical changes to the road and footway layouts.
- 5.3.10 At various sites, it was decided **not** to exclude some options even though footway widths and other parameters may be borderline or slightly below normal design standards for short lengths. A discussion about the viability of these options will be necessary after the issue of this report.
- 5.3.11 At some sites, specific signing, road marking and way-marking details will be essential to deliver the proposals. As many of these require DfT authorisation, the viability of the scheme if DfT authorisation cannot be obtained will need to be carefully considered.

## 5.4 Preliminary design concept options for specific problem sites

- 5.4.1 These concept design options and related design, cycle user and road safety comments are provided in Appendix 4.

## 5.5 Investigation of other problem sites

- 5.5.1 The other sites on the list were considered primarily through a desktop exercise, using plans, Internet viewing facilities and the expertise and experience of other Amey staff who have previously been involved in design issues at these sites.
- 5.5.2 Sketch concept layouts and brief notes about these options are provided in Appendix 5.

## 6 Consultation process

- 6.1.1 This study has not been subject to any formal consultation processes. However in meeting SCC requirements, there have been various initiatives to ensure that stakeholders were kept informed and were able to provide feedback during the course of the study, prior to the preparation of this study report. These were:
- Meetings at SYPTE – some of which were open to cycle groups
  - Presentations to SCC, SYPTE, Supertram and the Sheffield Cycle Forum
  - Sending out of information and draft proposals to stakeholders
  - Sharing of information, resources and proposals for consultation on a shared Internet drive specifically created for this purpose
  - Requests for comments and feedback on draft proposals – held on the Internet drive

- 6.1.2 Various comments were received on the main proposals in this report from cycle group representatives and other stakeholders later in the study period. This feedback will be used, in conjunction with the observations included in this report, to help Sheffield City Council decide which schemes to progress.

## 7 Strategic Issues

### 7.1 Design of tram/cycle specific signs and road markings

- 7.1.1 One of the problems indicated in the research that was carried out into other tram systems was that, even where new cycle facilities were provided to help cross the tram tracks, these were not always used effectively if they were inadequately signed and cyclists were not necessarily aware that they existed or what they were for. There are various examples of this on tramway systems worldwide.
- 7.1.2 In order to implement most of the proposals suggested in this report, it is considered that there is a need to provide high quality signing and road markings to clearly advise cyclists about the presence of any new cycle facilities and their purpose.
- 7.1.3 These signs and road markings are broadly of three types:
- Warning signs with plates
  - Direction signs of alternative routes with an indication that these are to avoid tram tracks
  - Road markings to support the above, as appropriate
- 7.1.4 An additional requirement that was identified was the need for some means of providing 'waymarks' on the road or footway surface to show cyclists the best way to cross the tram tracks, or to guide cyclists towards or through a facility. This is a concept that is widely adopted in USA and some parts of Europe, particularly using road markings for cyclists called 'Sharrows' (shared arrows) which are also used in relation to crossing tram tracks. No similar road markings exist in the UK. It is suggested that the installation of much smaller markings, possibly not much larger than road studs, but with some form of cycle marking on it could be effective for this purpose. These could possibly be blue and white to relate to current cycle signing.
- 7.1.5 There are currently significant limitations on providing appropriate signing and road markings to address all of the identified requirements for cyclists near tram tracks; currently none of these are authorised by the Department for Transport (DfT).
- 7.1.6 All road signs and markings in the UK should either be standard types (as specified in the Traffic Signs Regulations and General Directions 2002, which is currently under review and is due for update in 2015/16), or should have specific authorisation from DfT. It is therefore necessary to seek DfT authorisation for any new type or variants of signs and road markings that Sheffield might wish to use. This can be either on a site-specific or area-wide basis (e.g. for the whole of the Sheffield City Council administrative area).

7.1.7 Recent e-mail discussions with DfT about the specification of tramway specific signing for cyclists indicate that they would not support this for some of the options proposed and would be unlikely to authorise them. The process of obtaining signing authorisations may therefore be time-consuming to address at detailed design, and might not be successful. This represents a risk for some of the concept options proposed in this study which needs to be considered when deciding on which schemes to progress.

## 7.2 Alternative cycle routes

7.2.1 It has not been part of the brief for this study to investigate full routes for cyclists avoiding tram rails, and such routes have not been fully identified by Sheffield City Council (SCC).

7.2.2 SCC's approach to date has been to show the tram route on cycle maps and show other cycle routes in the same area, allowing cyclists to plan their own alternative routes.

7.2.3 Several other tramway systems, mainly in the USA, and also to some extent in Nottingham, have tried to address this matter by both identifying alternative routes and signing them on site to indicate that this is their purpose.

7.2.4 There would appear to be a strong case for positively identifying alternative cycle routes in Sheffield, publicising them in the media and signing them as alternative routes to the tramway on site. As indicated above, specifically signing these routes as alternatives to tram corridors may not find approval with DfT and this is something that would need to be addressed.

7.2.5 SCC has indicated that they might consider progressing this area of work as part of their future programme of cycle facilities.

## 7.3 Information and education for cyclists

7.3.1 Prior to the start of Supertram operation in 1993, there was considerable advance publicity, including various publications about safety for drivers, pedestrians and cyclists.

7.3.2 Other UK tramway systems, (e.g. Manchester, Edinburgh and Nottingham), have issued initial information and later, from time to time, including new media (e.g. YouTube videos), web site information and leaflets. Edinburgh has also provided cycle training showing how best to cross the tram tracks safely, a video of which is available on YouTube.

7.3.3 Current guidance for cyclists about crossing tram tracks is mainly that cyclists should cross the rails at 90 degrees or an angle as close to this as possible. This guidance is included in the section on tramways in the Highway Code (item 306), other cycling web sites and also on one of the SCC web site cycling pages.

7.3.4 As a result of some of the investigations carried out for this study, (see Section 9), it is considered that some of this guidance for cyclists could possibly be expanded and improved, especially as crossing tram rails at 90 degrees is often not possible. This could include information about others factors that could lead to cycle accidents when crossing tram tracks.

However, as the evidence for this is not yet fully validated, it might be felt that this would be premature until further research is carried out.

- 7.3.5 New guidance for cyclists which is specific to Sheffield might also usefully show problem sites and later any special facilities that are installed to assist cyclists.
- 7.3.6 It is understood that SCC offers free two hour cycle training sessions for any cyclist in Sheffield. It also offers Level 2 Bikeability training for school children. It is considered that it would be worthwhile for SCC to ensure that information about crossing tram tracks is provided as a standard part of this training. It would also be a useful opportunity to issue an updated information leaflet, if available, about cycling over tram tracks.
- 7.3.7 Additionally, it could be considered whether it might be possible to install a trial facility with tram rails away from live tramway somewhere in Sheffield and provide training sessions for cyclists as to how best to cross the tram tracks.

## 8 Possible Track Safety Improvements for Cyclists

### 8.1 Filling the gap and other methods

8.1.1 An alternative or complementary approach to providing special crossing or diversion facilities for cyclists to cross the tram tracks is to seek to improve the rail installation on-street in some way to make it safer to cross without the need for any specific local cycle facilities or diversion measures.

8.1.2 The primary method that has been proposed, and investigated in various places over a number of years, is the installation of a rubber or similar material insert into the gap alongside the top of the rail where the extended part of the tram wheel (the wheel flange) passes.

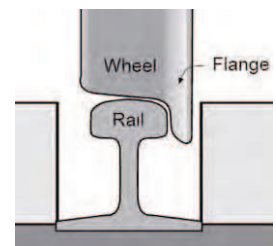


Figure 3 – Rail and Wheel Flange

### 8.2 Inserts into grooved tramway rail

8.2.1 There do not appear to be any solutions that involve installing a rubber or similar insert into a standard grooved rail. The basic problem with this is that the groove in the rail is only slightly deeper than the depth of the wheel flange of a passing tram. Therefore any material installed would need to reliably compress more than 70% and always spring back to full height (to the top of the rail). It is considered that it is very unlikely that even modern complex filler materials could achieve this and still have a useful product life.

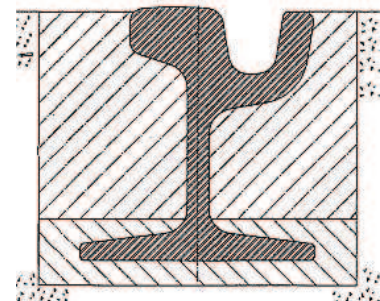


Figure 4 – Grooved tram rail in a concrete slab 'pocket'

8.2.2 As a result, none of the previous track flangeway filler trials appear to have been installed into a standard unmodified grooved tram rail. It has therefore been necessary to either cut the groove off the rail, or replace the grooved rail with a standard rail in an alternative arrangement.

### 8.3 Inserts alongside standard rail

8.3.1 Several arrangements have been tried where the grooved rail is replaced with a standard rail with a gap alongside the rail head and a larger filler block is then installed in the gap.

8.3.2 An early example of this is in Chicago, USA (Cherry St Bridge), although this is not a tramway. There are also other examples at level crossing type arrangements, primarily in the USA. It hasn't been possible to identify the filler products used at these sites but some might have been one-off specified materials for the particular location.

8.3.3 The common feature of these earlier arrangements is that they were mainly heavy rail crossings with a frequency of train passage and speed which was very low. On Cherry St Bridge, trains are less than one per week, and speeds are less than 10mph. This doesn't match the requirements that would be necessary for tramway operation.

8.3.4 The primary issue with flangeway (or groove) fillers is in finding a material that:

- Always compresses quickly and adequately when a tram wheel passes over it, under all weather and temperature conditions (as failure to compress properly could in theory present a potential derailment hazard)
- Can be securely fixed and is robust (i.e. doesn't break up through repeated compression and expansion cycles)
- Lasts a reasonable period before needing replacement
- Has a reasonable cost for installation, maintenance and replacement

8.3.5 A trial of a prototype arrangement of this type was installed on a short operational section of the tramway system in Zurich, Switzerland in 2013. In this trial, the flangeway filler used was a solid polymer material. This was carefully monitored, and whilst it met the initial requirements of cyclists, reducing the problems of crossing the rails, the material degraded after a short period and had to be removed in 2014. Feedback from the tram operator about the trial noted:



Figure 5 – Zurich prototype gap filler

*“The participants considered the new design as being mostly much better than conventional tram tracks, with the bicycle tyres no longer being bound by the tram tracks. However the risk of slipping on the rails with and without the rubber infill was felt to be about the same, even though the tyre grip on wet tram tracks with the rubber infill was better. Participants in the tests could ride the new tram rails much more safely and were more relaxed as they no longer had to cross the rails at a right angle.”*

8.3.6 The cost of installation of the Zurich trial was about £2600 per linear metre of track, which the Zurich operator felt was too expensive for wide-scale operational use, and there were also additional monitoring costs. The project managers have advised that another trial, with a revised arrangement and a new material, is anticipated at some later date but there are as yet no firm proposals.

8.3.7 Another recent example of a similar type on a tramway/streetcar system was installed in very short sections at some pedestrian crossings across service tracks on the First Hill section of the new streetcar (tram) system in Seattle, USA in 2013. This filler product has an open box compressible section and a corrugated surface texture. However, the system designers and product manufacturer have indicated that this product is not designed for sections used for normal streetcar service operation frequencies, and therefore cannot be installed on the main routes on their system.

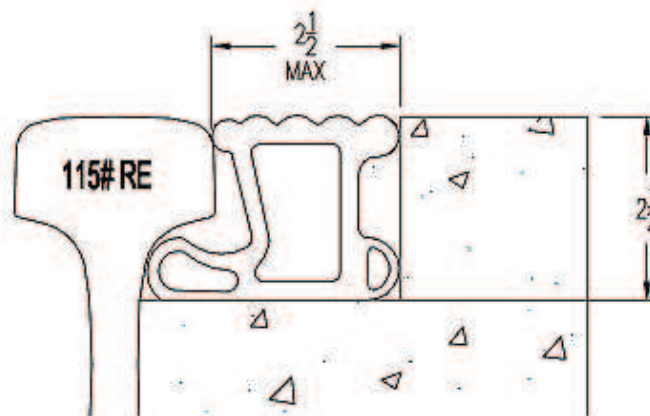


Figure 6 – Seattle gap filler –  
for low frequency usage

8.3.8 Unfortunately, after making various enquiries, it has not been possible to identify a suitable product or material that can be used in a ‘pocket’ (large gap for the rail and surrounding material – see figures 3, 4 and 5 above) in the tram track slab, such as is used in Sheffield, that meets all the criteria in section 8.3.4 above, for use on an operational part of a tramway system with normal service frequencies.

## 8.4 Other gap filling arrangements

- 8.4.1 An alternative approach which is particularly suited for use at level crossings is using a product called veloStrail. This involves installing a series of interlocking rubber-like components which are clamped between the rails across the area of the level crossing.



Figure 7 – veloStrail installation at a level crossing

- 8.4.2 This product differs from other flangeway fillers and appears to be more robust as it has a compressible honeycomb construction alongside the rail, and also has some opportunity to flex and deflect within the unit.



Figure 8 – veloStrail insert

- 8.4.3 After a period, if a compressible section no longer returns to close to its previous level, it is possible to replace just that section with another standard insert quite quickly.
- 8.4.4 This product has recently been approved for use in the UK (at level crossings) by Network Rail on main line railways with operating speeds up to 70mph. The product is also in use on railways worldwide and has now been installed at two skewed level crossings in the UK to assist cyclists and pedestrians (A684 Bedale Rd, Aiskew and Spring Bank West / Walton St, Hull). However, these approvals do not relate to use on tramways which operate under different conditions, often with much greater tram frequencies. For tramway use, the system would have to be approved by the tramway operator and probably also by the Highway Authority (e.g. local Council) and the Office of the Rail Regulator (ORR).
- 8.4.5 This product is not very well suited for use on most tramways in on-street sections as it cannot be installed in narrow pockets alongside the rails (as used in Sheffield) but instead requires sections to be installed in the full area between the two rails. It is therefore more suited to ballasted track construction or for standard tram rails mounted on top of a concrete slab.
- 8.4.6 Two trials have been carried out on sections of the on-street tramway in Geneva around 2011. These involved replacing the whole central section of the track bed to allow these components to be installed on-street. It is understood that the system is still in use at these two locations, and that the compressible components are only just due to be replaced for the first time. However the tramway operator, TPG Geneva, have advised that the system is not approved for general use by the federal authorities in Switzerland. They have indicated that

maintenance costs are increased by comparison with other trackwork arrangements and that they would only use the system in targeted locations, as their preference is to improve cycling safety through segregation of cycles and tramway infrastructure.

8.4.7 Installation of veloStrail on existing ballasted track is likely to cost around £1200 per linear metre, but retrofitting onto existing slab track (by removing the centre section) could cost as much as £5-6000 per linear metre. Retrofitting to on-street tramways in the UK could also have other more complex and not insignificant implications. These include controlling the spacing between the rails (the rail gauge - which is currently controlled by the slab pocket positions); and stray current protection measures (which prevent electrical leakage from the rails to underground pipes and equipment) which are often connected to reinforcement metalwork in the track slab and which would need to be removed for veloStrail installation. However these matters are very dependent on the original method of tram track installation.

8.4.8 One option that could be considered is whether installation or replacement with veloStrail over just a small part of a road crossing might be viable, for example just in the section where a cycle lane on-street crosses the tracks. A short section of an arrangement of this type was installed in Geneva and is still in operation. Whilst this may be costly, it might be more effective and cheaper than providing separate cycle facilities on some tramway systems. However, it still has the same problems of installation within concrete track slab construction so is unlikely to be viable to retrofit on the tramway in Sheffield.



**Figure 9 – short veloStrail insert section across a cycle lane - Geneva**



- 8.4.9 More generally, veloStrail could therefore potentially be a useful option to consider for new tramway lines and extensions, where the tracks need to cross road carriageways at acute angles, possibly just for short sections across cycle lanes. This would need to be considered early in the design process. However it is unlikely to be viable for general use for in the on-street running sections of most tramways, either for new lines or for retrofitting later.
- 8.4.10 Although veloStrail should be effective in preventing cycle tyres getting stuck in the gap alongside the rail, in view of the comments made by the tram operator about the gap filling trial in Zurich, it is unclear whether it would also prevent cyclists from sliding on the rail head.

## 8.5 Rail surface

- 8.5.1 It is well known that the rail head of all rails is generally a smooth and often shiny surface, and as would be expected, this has low skid resistance by comparison with other materials (such as tarmac) particularly in wet weather conditions.
- 8.5.2 It is generally believed that this low skid resistance contributes to cycling accidents on tram tracks, with sliding occurring either on the rail head or on the edges of the rail groove.
- 8.5.3 It was queried whether a smooth surface was absolutely necessary, and whether a durable surface texture and skid resistance could be added to rails without adversely affecting tramway operation.
- 8.5.4 Initially this proposal seemed unlikely to be viable. However, after some investigation, an extremely durable bonded metal coating was found that has almost identical skid resistant properties in dry and wet conditions. If this could be applied to tram rails and could sustain frequent tram passage, it could potentially have a significant effect on cycling safety over tram tracks.
- 8.5.5 Work is now in progress with a coating contractor and with Sheffield University to test such materials for various properties to see if they might be suitable for use on tram rails. The results of these tests should be available later in 2015.

## 8.6 Conclusion – rail issues

- 8.6.1 At present, there appears to be no practicable solution (in relation to the rail installation itself) for improving the safety of cyclists crossing tram rails at acute angles except possibly at vehicular (level) crossing locations.
- 8.6.2 However it seems feasible that treating the rail with a skid resistant coating or installing a robust filler in a pocket alongside a standard tram rail on-street, or a combination of these two techniques, could be feasible at some point in the future but possibly only if suitable coatings and materials are developed specifically for tramway operational requirements.
- 8.6.3 If such products were available at a reasonable cost and could be shown to be both durable and effective, it seems likely that this could make a significant contribution to cycle safety around on-street tramways.

---

## 9 Cycle / Track Interfaces and Advice for Cyclists

### 9.1 Theoretical matters

9.1.1 When looking at current guidance for cyclists, there appears to be little understanding of the precise causes of cycle incidents at a theoretical level. For example, it is widely stated that it is safest to cross the tracks at 90 degrees. In various places it is also advised that it is better to avoid crossing the rails at less than 45 degrees, 60 degrees or 70 degrees, depending on the source of the guidance. However there appears to be no evidential justification for any of this advice.

9.1.2 In order to improve guidance for cyclists, it is important to improve our understanding of the reasons and mechanisms of how cycle tyres slide on tram tracks and how wheels drop into the rail groove.

9.1.3 In the investigations in this study, various parameters were considered:

- Dimensions and profile of the rails (shape and width of groove)
- Height of rail above surrounding areas
- Angle of crossing
- Tyre width and general type
- 'Trail' of the bicycle (this is a cycle design parameter)
- Effects of pedalling, steering, leaning and braking on traction and grip on the rail
- Friction / grip characteristics (coefficients) of tyres on different surfaces – e.g. tarmac, concrete, polymer (alongside rail), the air gap (over the groove) and steel

9.1.4 Other related parameters that could have some effect but could not be taken into account in the assessment, or were considered might have limited effect, (although they could be considered further in additional modelling later) were:

- Size, length and width of the tyre contact patch (the normal area of contact between the tyre and the ground – although this changes when crossing a gap)
- Tyre material and type of tread
- Tyre compression and 'sticky' effects between the tyre and the rails
- Effect of two wheels riding on different surfaces at the same time
- Speed of crossing the rails
- Differences between pedalling and freewheeling across the rails
- Where the cyclist is pedalling across the rails, the effect of the rear cycle wheel being powered (by pedals), whilst the front wheel is not (this could relate to potentially different situations for front and rear wheel slides)
- Oscillating movements – due to weaving, wobbling and pedalling (which could affect the stability of the bicycle whilst crossing the rails)

9.1.5 Whilst our analysis was preliminary, and more comprehensive modelling may be able to model these factors in more detail and include some of the other parameters listed above, we felt that there are two areas that are particularly worth noting: Traction circle theory and the angle of crossing the tracks.

## 9.2 Traction circle theory

9.2.1 This theory is widely used in motor-cycling and motor racing but is not well known outside these areas. In effect, this theory indicates that given the traction (or grip) between any particular combination of tyres and the surface underneath (normally a road surface), the grip can only resist a certain level of forces in different directions which may be used for braking/accelerating, and cornering/steering (for cars) or steering/leaning (for cycles).

9.2.2 It should be noted that Traction Circle theory is based on the laws of physics and is not related to the performance of any specific cycle or vehicle (for accelerating braking, cornering, steering, etc.). However in practice, whilst the shape of the traction circle may vary depending particularly on tyre characteristics, this is only likely to affect vehicle and cycle racing.

9.2.3 The amount of traction varies for different tyre / surface contacts (e.g. the traction is much greater for a tyre on tarmac than on wet steel).

9.2.4 Traction theory dictates that whilst it may be possible to brake or accelerate hard in a straight line, or corner (or steer or lean) severely on a particular surface, it is not normally possible to do both to the same degree at the same time.

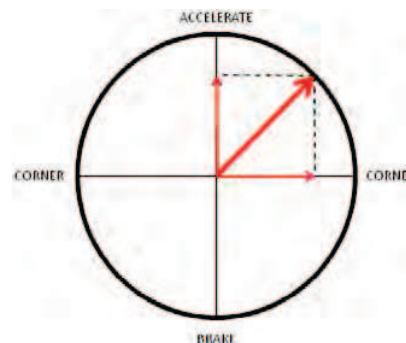


Figure 10 – Traction Circle

9.2.5 In motor sports, the primary objective arising out of this theory is to push the limits on how much it is possible to brake/accelerate and corner/lean in different situations and on different surfaces without losing control and skidding (which occurs when the forces involved move outside the traction circle).

9.2.6 In relation to cycle / tram rail safety, the primary concern is how cyclists can stay as close as possible to the centre of the traction circle (which reduces when crossing the tram rails, as the friction coefficient is lower than for steel than for tarmac or concrete) to avoid slipping on the rails.

9.2.7 In effect, whilst acceleration is not really an issue for cycling (as the pedal driving force is small), this dictates that in order to maximise stability and minimise the risk of slipping when crossing the tram tracks, cyclists should avoid braking or steering/leaning when crossing the tram tracks.

9.2.8 It should be noted that using this advice may conflict with current cycle guidance in some situations. For example, if a road layout dictates that cyclists should take a tight curve first in

order to cross the tracks at 90 degrees, then this might mean that the bicycle is still leaning at the moment of crossing the tram tracks.

9.2.9 This implies that in some circumstances it might be safer to cross the tram tracks riding fully vertically (without steering/leaning) in a straight line at a slight angle (e.g. 60 degrees, or possibly less on a dry rail) to the tracks rather than steering/leaning in order to cross the tracks at 90 degrees.

9.2.10 Unfortunately, it has not been possible to quantify the relative effects of these two factors in determining the safety of crossing the tracks as part of this study.

9.2.11 Further details of Traction Circle theory are provided in Appendix 7.

### 9.3 The angle of crossing the tracks

9.3.1 An initial analysis has been carried out of the effect of the angle on crossing the tram tracks, and in particular in crossing the groove in the rail which is about 41mm wide on the new rails in Sheffield. This analysis is unable to take full account of variations in tyre types and materials, and the tyre contact patch length or width. Also no account is taken of complex tyre compression and adhesion processes.

9.3.2 The analysis is shown in Appendix 8.

9.3.3 It should be self-evident, that as the angle of crossing the tracks reduces (from 90 degrees towards 0 degrees), the distance across the rail head and across the gap increases, particularly for very acute angles (e.g. for a tyre of theoretical zero width, the 41mm gap on a 90 degree crossing would increase to 120mm at 20 degrees).

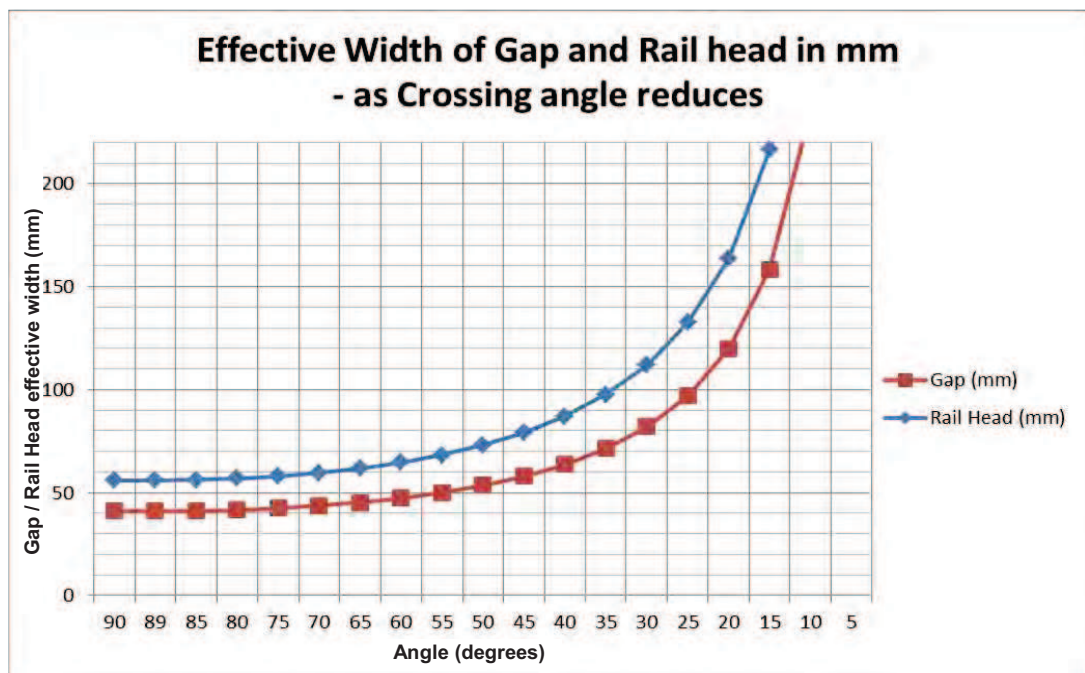


Figure 11 – Change of effective Gap and Rail Head width at different angles

- 9.3.4 This means that as the angle reduces:
- The effective width of steel rail to cross increases, so that assuming that some slipping takes place on the top of the rail head, the chance of cycles sliding will also increase
  - The effective width of the gap in the rail groove also increases, so that at a certain point, the length of the normal contact patch might not be long enough to bridge across this gap. In this situation, the tyre would effectively start to drop into the groove before reaching the other side of the rail (unless the tyre width and tread prevent this from occurring).
- 9.3.5 The main other issues highlighted by this analysis are that, as the angle of crossing reduces, and the width of the gap effectively increases:
- The lowest point of the tyre drops further into the groove
  - The forces on either side of the tyre create an increasing twisting effect on the steering, effectively twisting the wheel into the groove
  - The forces on either side of the tyre also increase the sliding effect on the tyre contact points on each side of the groove, which might lead to slipping or sliding into the groove
- 9.3.6 It is not clear if some or all of these effects are directly proportional to the angle of crossing, and/or whether some threshold may be pertinent (e.g. when the effective gap exceeds the normal contact patch length).
- 9.3.7 It is noted that the contact points on the side of the tyre are likely to change as the angle changes, and this could be unique to different types of tyres and wheel sizes which makes analysis of this effect complex.
- 9.3.8 However because the increase in the width of the gap as the angle reduces is an exponential curve, and the increase is not very significant until the crossing angle is less than 60 degrees, it is considered likely that these effects will be small between 90 and 60 degrees, and may even be acceptable for most cyclists up to 45 degrees riding across dry rails.
- 9.3.9 It should be understood that this is an initial analysis and it is not clear to what extent these effects are exacerbated or reduced by other effects that might also be occurring. This could therefore be the subject of further work on modelling these situations at a high academic level.

## 9.4 Advice for cyclists

- 9.4.1 It is difficult with the limited analysis carried out in this study to recommend firm advice to cyclists over and above what is already known.
- 9.4.2 If the angle of crossing and the related increase in effective width of the rail and gap that has to be crossed is proportional to the likelihood of sliding, twisting of the steering and dropping into the groove, due to several factors, then the graph of angle  $\nu$  gap width may be a useful guide as to what are acceptable crossing angles in most conditions. This would suggest that crossing at down to 60 degrees (or possibly less in dry conditions) might be acceptable for most cyclists.

- 9.4.3 Cyclists could also usefully become more aware of traction circle issues, and wherever possible avoid (or minimise) braking and leaning when approaching and crossing tram tracks. Where there is conflict between the angle of crossing and leaning (due to turning), it is worth noting that it might be preferable to cross at a lesser angle to avoid leaning whilst crossing, rather than cross at 90 degrees.
- 9.4.4 A short-term project is now in progress at Sheffield University about the safety of cyclists crossing tram tracks considering options for safety improvements, and it is possible that some of that work might also increase our understanding of these issues so that improved advice can be given to cyclists.

## 10 Conclusions

- 10.1.1 The original primary focus of this report was to look at site specific measures to improve the safety of cyclists at known problematic locations around the tram network. This was to be based on research into methods that have been used to improve cycling safety on other tramway systems.
- 10.1.2 The research carried out has provided useful indications as to how best to approach tramway cycle issues, particularly where the tracks cross or move across the carriageway at acute angles. Unfortunately many of the methods have been shown to be difficult to employ at sites in Sheffield and on other tramway systems, due to constraints such as existing minimal footway and carriageway widths, and extensive pedestrian activity in footway areas.
- 10.1.3 Several preliminary design concept options for various problem sites in Sheffield are included in the Appendices to this report. It is anticipated that decisions on which options should be progressed will be made after the completion and distribution of this report, involving discussions between Sheffield City Council and relevant stakeholders.
- 10.1.4 With the agreement of Sheffield City Council, we have jointly widened the scope of the study to investigate other aspects that could potentially improve the safety of cyclists on tramways. This has included initial investigations into some aspects of the mechanism for how cycling accidents might be occurring, which might improve guidance for cyclists on how to cross tram rails.
- 10.1.5 Options for groove fillers and similar products which are much reported elsewhere as an apparent panacea for resolving cycle accidents on tram tracks have also been investigated. Unfortunately we have found that most of these are currently not viable for use in Sheffield and probably on most other UK tramways. However there is some prospect that these could be developed further to become more viable in the future.
- 10.1.6 The study has also led to useful interactions with the University of Sheffield, where as a result, it now has students carrying out a project looking into problems of cyclists crossing tram rails, with a wide brief. It is also assisting us with the testing of some special coating materials to see if they might be suitable to improve the skid resistance of tram rails.
- 10.1.7 Due to problems with the collection of cycle accident data, both in relation to tram tracks and elsewhere, it has been suggested that SCC should develop a facility to add a reporting mechanism for this on its web site, with some items that are specific to cycle / tram rail incidents. If suitably publicised amongst cycle groups, this could provide a better evidential base for future investigations and the consideration of site specific treatments.
- 10.1.8 Options for replacing the red surface areas alongside the tram tracks in some locations in Sheffield, to deter drivers from driving on the tram rails, were also investigated. The final proposals to replace with hatched markings is considered to be the most viable and cost-effective solution whilst at the same time providing a clearer message to cyclists.

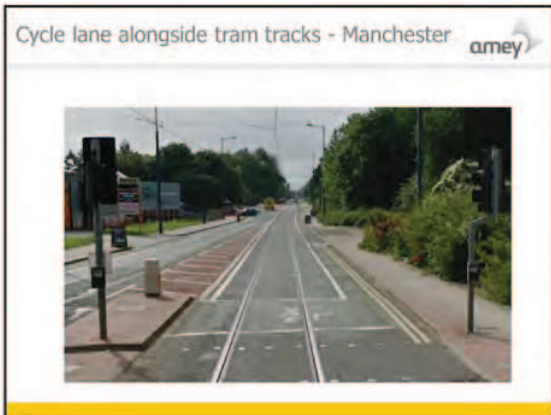
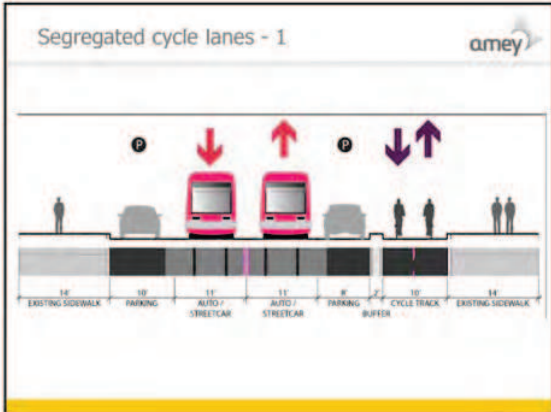
## Appendix 1

### Cycle Facilities and Traffic Management on other systems



Segregation amey

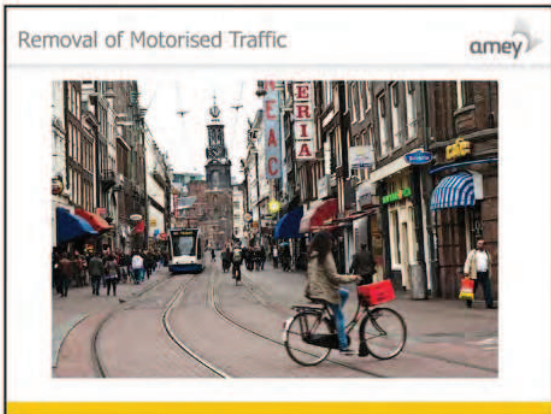
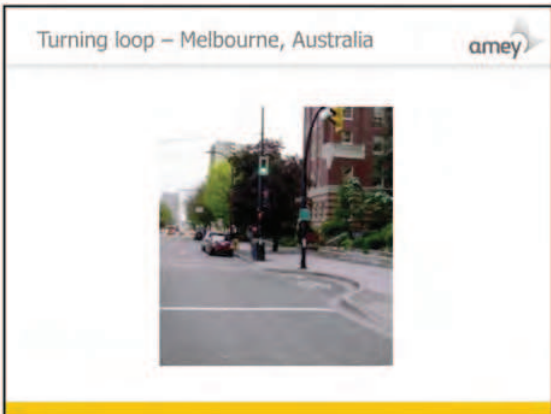
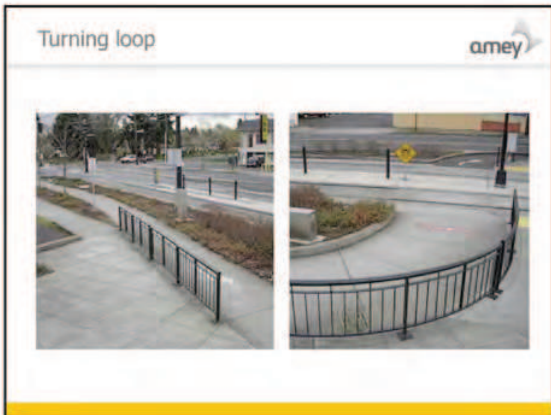
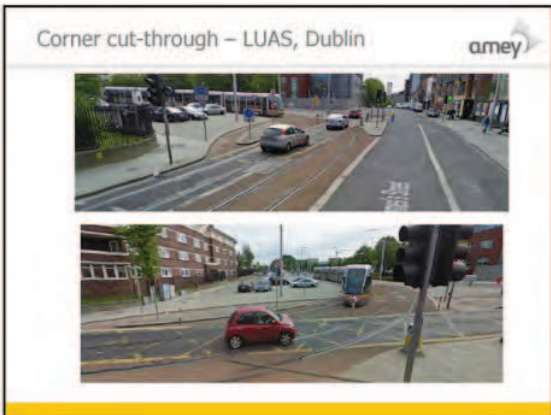
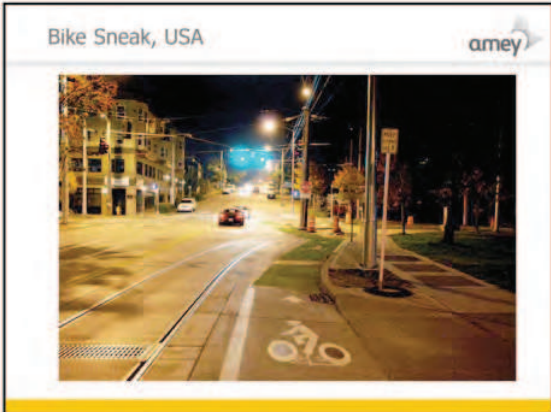
- Segregation from tram tracks
  - Cycle Lanes
    - Separated by a hard strip
    - Separated by a white line (or road markings)



Localised Physical measures amey

- Physical measures
  - Tram stop bypass lanes
  - Other measures to guide cyclists across track at correct angle
    - Bike 'sneak'
    - Corner cut-through
    - Loop to one side of road (e.g. Melbourne Nook, Jug Handle)





Signs & Road Markings amey

- **Traffic Management - Signing, Lining and Signal**
  - Hazard/Warning Signs
  - Advisory signs - how to cross tracks
  - Signs for alternative cycle routes
  - Road Markings - guided path to cross tracks
  - Approach Cycle lanes – at junctions and signals

Warning Signs - 1 amey

Warning Signs – 2 (UK type) amey

Tram crossing – advisory signs amey

Signing for Cycle alternative routes (UK) amey

Road markings - 1 amey

Amsterdam  
(Elephant's feet)

Road markings - 2



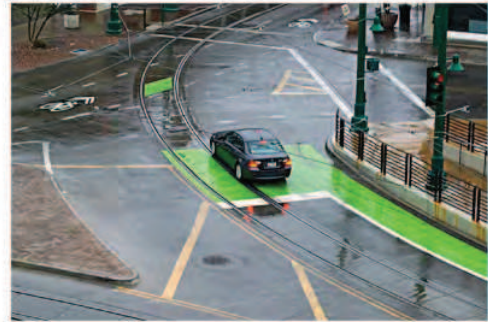
Road markings - 3



Tram – Road markings - 4



Tram – Road markings - 5

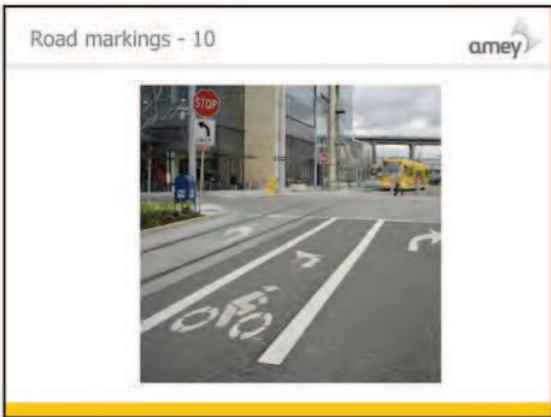
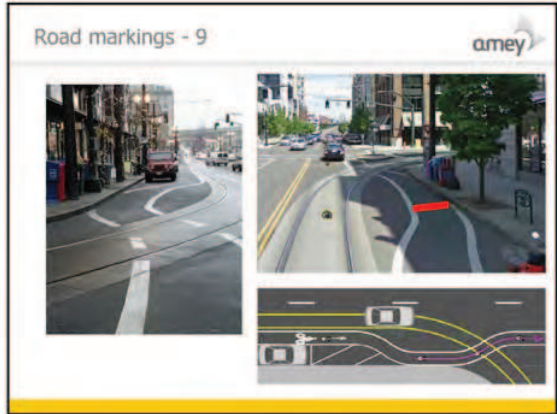
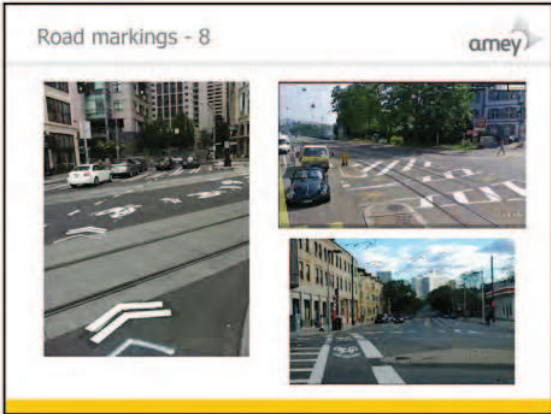


Tram – Road markings - 6



Road markings - 7





## Appendix 2

### Red Surface Areas – Options for Replacement

## Red surface areas – Replacement Criteria



- Replacement Criteria:
  - Remove (or not replace) red textured surfacing
    - (due to cost and maintenance costs)
  - Still needs to deter drivers (of motorised vehicles) from driving on tram tracks
  - Change perception of cyclists of this area
    - It should not be seen as a reduced width cycle lane
  - Preferably – still allow some access by cyclists
    - Even though not primarily for cycle use

## Options to replace Red Surface areas



Existing White Line and Red Surfacing

## Options to replace Red Surface areas



Existing (White Line?) and Red Surfacing

## Options to replace Red Surface areas



Existing White Line and Red Surfacing

## Options to replace Red Surface areas



Existing White Line and Red Surfacing

## Options to replace Red Surface areas



- Investigate options
  - Remove all existing treatments – no replacement
  - Other textured surfacing
  - Hatched areas (white lining)
  - Simple line markings
  - Alternative line markings
    - Rainline
    - Ribline
    - Vibraline
    - Weatherline
    - Weatherline plus
    - Line marking & textured surfacing in narrow strip

Options to replace **Red Surface** areas amey



Prismo Rainline

Options to replace **Red Surface** areas amey



Prismo Vibraline – WJ RibLine

Options to replace **Red Surface** areas amey



WJ – Dot and Line – Weatherline Plus

Options to replace **Red Surface** areas amey



WJ – Weatherline Plus - variants

Options to replace **Red Surface** areas amey



Other textured road markings (not UK)  
(would need to be white in UK)

Hatched Markings in Edge Strip - Nottingham amey





Hatched Markings in Edge Strip - Nottingham



Hatched Markings in Edge Strip - Nottingham



Hatched Markings in Edge Strip - Nottingham



## APPENDIX 4

### Preliminary Design Concept Options for Problem Sites

## Introduction

This Appendix provides details of options that have been developed to try to resolve problems that cyclists encounter at various locations across the Supertram System, mainly as a result of needing to cross the tram rails at a shallow angle.

Whilst the options indicated here have been influenced and informed by research carried out into design techniques on other tramway systems worldwide, as will be seen in the notes for these arrangements, there have still been significant design issues at most sites. Most of these schemes therefore involve some compromises between different design parameters, which will have to be discussed by stakeholders before deciding on which schemes to progress.

All of these schemes, by their nature, involve a diversion of cyclists away from their preferred desire line along the road. This results in longer paths through junctions and slower progress along the route. This has to be balanced by the increase in safety that these facilities could provide, at least for some cyclists and particularly in poor weather conditions.

However common issues on many of these schemes are:

- Longer route for cyclists, to avoid crossing tram tracks at acute angles
- Narrow footways that need to become shared use with cyclists:
  - Might not meet current design standards for shared use (possibly just for short lengths)
  - Often difficult to widen due to constraints of the carriageway or features behind the footway (e.g. buildings, walls, limit of highway, etc.)
  - Where possible to widen, it could be costly
- Conflicts between converting footways to shared usage and significant pedestrian activity
- Alternative cycle routes having significant gradients that might not be attractive for cyclists
- Alternative cycle routes through areas with other problems (e.g. narrow roads, industrial use and parked cars)
- Some of the signs and road markings required for these options would need Department for Transport authorisation, which it has been indicated might not be given

The arrangements included in this Appendix might therefore be seen as the best options available within the current constraints at each site. However it would be understandable if they are not regarded as full solutions of the problems.

## Format of this Appendix

This Appendix is divided into separate sections for each of the eight sites that have been investigated. In each section the notes are broken down into five areas:

- Notes on the location and problems of the site – with a site photo
- Descriptions of the options that have been developed – by the Amey design team
- Cyclist usability comments – by Amey personnel
- Road Safety comments – by Amey personnel
- Budget cost estimates for the different options

The Cyclist usability and Road Safety comments on these proposals have intentionally been produced separately from the design team, to give an independent view of the proposals.

## 1. SHALESMOOR

Shalesmoor tram stop is located to the north of the City Centre next to the Inner Relief Road. It is part of the yellow and blue routes which link the north of Sheffield as far as Middlewood to the City Centre. The area of concern is the section of tram tracks which cross the carriageway at Hoyle Street at a 35 degree angle. A cycle lane is marked across the tracks in this area. Reported accidents at this section include cyclists who have slipped on the rails while proceeding ahead from Hoyle Street towards Penistone Road. The conditions for these accidents were reported as wet.



### Traffic Management Proposals

For both of these options the existing cycle lane which runs through the tram tracks should be removed.

#### Option 1

Option includes an area of shared footway with relevant shared footway signage to create a facility for cyclists to leave the main carriageway to avoid the tram tracks. Cyclists can return to the main carriageway by firstly crossing the tram tracks at the pedestrian crossing point (at 90 degrees) and then re-joining at Penistone Road. The shared footway area could contain some cycle symbols and red surfacing to enhance the area if necessary and also some relevant shared footway signage particularly where pedestrians and cyclists interact. Some thought needs to be given to the surface of the shared area as it is currently flagged paving stones which could be hazardous. In addition to this, some further physical works including dropped crossings would be required to provide access and egress points. At this particular location a second dropped crossing could be provided as a back-up if the first access point was missed. Some existing street furniture will need to be moved. Signage would include some advance direction signs, some hazard signs for cycles to warn of slippery rails and route signage to show at what point to cross the tram tracks. Department for Transport (DfT) approval would be required for some of these signs (Drawing number (Dwg No.) 001).

### **Option 2** (*probably no longer viable due to recent new guard rail installation*)

Option includes an area for cyclists to leave the carriageway and re-enter so that they cross the tram tracks at approximately 70 degrees. The area could be a channel or on the footway. The crossing area which is on the carriageway could be highlighted using the new cycle markings and some red surfacing if necessary and cyclists manoeuvring across this section would be assisted by the existing traffic signals and a new cycle signal that would operate when both traffic and trams are stopped in this area. Some physical works would be required to create the channel or to change the surface of the existing footway as this is currently block paved. Signage would include some hazard signs and route signage to show the channel area and the crossing point. DfT approval would be required for some of these signs (Dwg No. 002).

## **Alternative Route Proposals**

Option includes an alternative route for cyclists avoiding the tram tracks on Hoyle Street. The route would use the carriageway rather than footways. Signage would direct cyclists away from Netherthorpe Road onto Meadow Street. Repeat signage could be erected at each junction along the route. DfT approval would be required for some of these signs (Dwg No. 003).

### **Option 1**

Route: Netherthorpe Road to Infirmary Road/Penistone Road via Meadow Street, Water Street, Matilda Street and St Philip's Road (approx. 500m). Some physical work features would be required at the end of St Philips Road (junction with Infirmary Road) to create an egress point for cyclists to re-join the main carriageway. Some cycle symbols could be included at the dropped crossing area. Also, some new cycle markings could be installed to advise of cyclists crossing Infirmary Road from St Philip's Road and some shared signage where pedestrians and cyclists might interact.

### **Option 2**

Route: Netherthorpe Road to Infirmary Road/Penistone Road via Meadow Street and Henry Street (approx. 400m). Some physical work would need to take place to create an egress point for cyclists to re-join the main carriageway. Further physical works are required to create a formal crossing point over the tram tracks to link Henry Street with Penistone Road. Some shared signage should be installed, particularly where pedestrians and cyclists interact, and where cyclists cross the tram tracks, as visibility here is restricted. Some existing signal controlled pedestrian crossing points at the bus egress junction on to Penistone Rd would also need to be converted to far-sided Toucan facilities.

## **Cyclist Usability comments**

### **Traffic Management Proposal Option 1**

At the point where the proposed cycle path begins, there are multiple obstructions on the footway, from lighting columns to electrical boxes to sculpture. The available width between these obstructions and the kerb appears to be about 2m, which should be more than sufficient for a dedicated cycle lane. Staying this side of the obstructions would also reduce the chance of conflict with pedestrians. There are footway obstructions at the corner just before the tram stop, and visibility is quite poor. However, given a dedicated path and clear signage, these problems should be minimised.

Using the existing pedestrian crossing to cross the tram tracks would entail quite a sharp turn even if the whole crossing was clear. If this could be widened and segregated the chance of conflict with pedestrians would be minimised. The proposed path from here on directs cyclists back onto the main road ahead of the traffic lights. Normally this might be seen as an advantage but it could potentially place cyclists in conflict with motorists who, given the green light to enter the roundabout from Shalesmoor, might reasonably expect to have right of way. This is not such a problem for cyclists turning left into the dedicated cycle lane at the start of Penistone Rd, but it might be for those taking advantage of the Hoyle St red light to cross the two lanes to continue round the roundabout. A key

issue is whether a cyclist can cross these two lanes (from a slow or standing start) before a car can get from the Shalesmoor lights to that point. This is a distance of around 80 metres, which could be covered in 6 seconds if the car entered the roundabout at 30mph. The distance the cyclist must cover in the same time is around 30m, which is possible, but could be challenging for some cyclists.

### **Traffic Management Proposal Option 2** (*probably no longer viable – see above*)

This option involves a much shorter path in the form of a short turning loop, designed to direct cyclists across the tram tracks at a safe crossing angle. A new cycle signal would be provided to indicate to cyclists when trams and vehicles are stopped, and it is safe to proceed into the carriageway. Cyclists would then be free to move up to the advanced stop line at the signalled roundabout and wait for that light to turn green. However in trying to get the best angle to cross the tracks, shown as 70 degrees, cyclists would not arrive at the best location in the carriageway. Some further relaxation of the crossing angle, perhaps down to 50 degrees, might allow cyclists to obtain a better position and permit them to take a smoother and faster path to the advanced stop line.

### **Alternative Route Proposal Option 1 and 2**

Both options shown here seem satisfactory, with the caveat that the exit from Henry St gives poor visibility of approaching trams and also involves a footway crossing, as does the exit from St Philip's Rd. However, as Malinda St has priority over Roscoe Rd and Henry St, an alternative might be to direct cyclists onto a path for the same position as in Option 1, then along Malinda St and down Watery St, whose junction with Infirmary Road also offers much better visibility.

## **Road Safety comments**

### **Traffic Management Proposal Option 1**

#### Problems

- Flagged paving is a risk.
- Available widths for shared use?
- High pedestrian levels in vicinity of student accommodation frontage and at tram stop, particularly with alighting passengers.
- The slip off to the footway may result in slow manoeuvring cyclists getting shunted by following traffic.
- The merge back onto carriageway at Penistone Road is in an area of high conflict there are high levels of lane changing and the cyclist would emerge at this point.

#### Advantages

- It follows the route pedal cyclists want to follow and is the most direct.

### **Traffic Management Proposal Option 2** (*probably no longer viable – see above*)

#### Problems

- The pedal cyclist would be directed towards the offside of the carriageway and have to move back towards the nearside to continue onto Penistone Road.
- New road markings for cyclists might be a skid hazard to other road users particularly powered two wheelers.

#### Advantages

- Signal control for cyclists using this facility

## **Alternative Route Proposal Option 1**

### Problems

- Convoluted route which may result in cyclists remaining on the original route.
- Crossing Infirmary Road at St Philips Road, may conflict with turning traffic from/to north eastern leg of St Philips Road.
- Crossing footway at Infirmary Road/St Philips Road may surprise pedestrians and lead to conflicts with them (however the pedestrian volumes at this location are lower than the other options presented.)
- Cyclists may encounter a number of manoeuvring service/goods type vehicles in this largely industrial area.

### Advantages

- Crosses tram tracks at right angles.
- Joins Penistone Road at the most appropriate point – controlled (ASL at the traffic light controlled junction?) and away from other conflicts.
- With appropriate measures most of the problems highlighted could be overcome.

## **Alternative Route Proposal Option 2**

### Problems

- Cyclists emerging at Henry Street onto Infirmary Road would have limited visibility with pedestrians and other traffic. (Pedestrian levels at this point are higher than option 1.)
- The crossing of the bus/taxi lane at Infirmary Road/Penistone Road may lead to conflict
- Existing pedestrian crossing(s) would need upgrade to Toucan.
- Cyclists re-join the carriageway (Penistone Road) at a location where there is a lot of lane changing and likely to lead to conflict.
- Cyclists may encounter a number of manoeuvring service/goods type vehicles in this largely industrial area.

### Advantages

- Less convoluted than Alternative Route Option 1
- Crosses tram tracks at a better angle

Road Safety considers the Alternative Route to be a safer option. This provides the most benefit for cyclists who are less confident of riding 'with the tram tracks'. The benefits of joining Penistone Road at a point away from Shalesmoor (as per option 1) is a definite advantage and should be safer overall for those cyclists choosing this route.

## Shalesmoor – Budget Estimates

### Traffic Management Proposals

Estimate

#### Option 1

2 No. Cycle Crossings off Hoyle Street	£3000
New Cycleway	£4400
+ Red Surfacing	£1100
Cycle Crossing on to Penistone Road	£1500
Traffic Signs and Lines	£1500
<b>TOTAL:</b>	<b>£11500</b>

#### Option 2 *(probably no longer viable – see above)*

Cycle Crossing off Hoyle Street	£1800
Removal / Replacement of paving	£5000
New Cycleway	£900
+ Red Surfacing	£300
Cycle Crossing on to Penistone Road	£1300
Traffic Signs and Lines	£1000
Traffic Signals & cycle detection	£8500
<b>TOTAL:</b>	<b>£18800</b>

### Alternative Route Proposals

Estimate

#### Option 1

2 No. Cycle Crossings at St Philip's Road	£5000
Traffic Signs and Lines	£1100
<b>TOTAL:</b>	<b>£6100</b>

#### Option 2

2 No. Cycle Crossings at Henry Road	£5000
Cycle Crossing on to Penistone Road	£3200
Traffic Signs and Lines	£1300
Upgrade pedestrian crossings to Toucans	£3500
<b>TOTAL:</b>	<b>£13000</b>

## Notes

### Construction costs estimate only

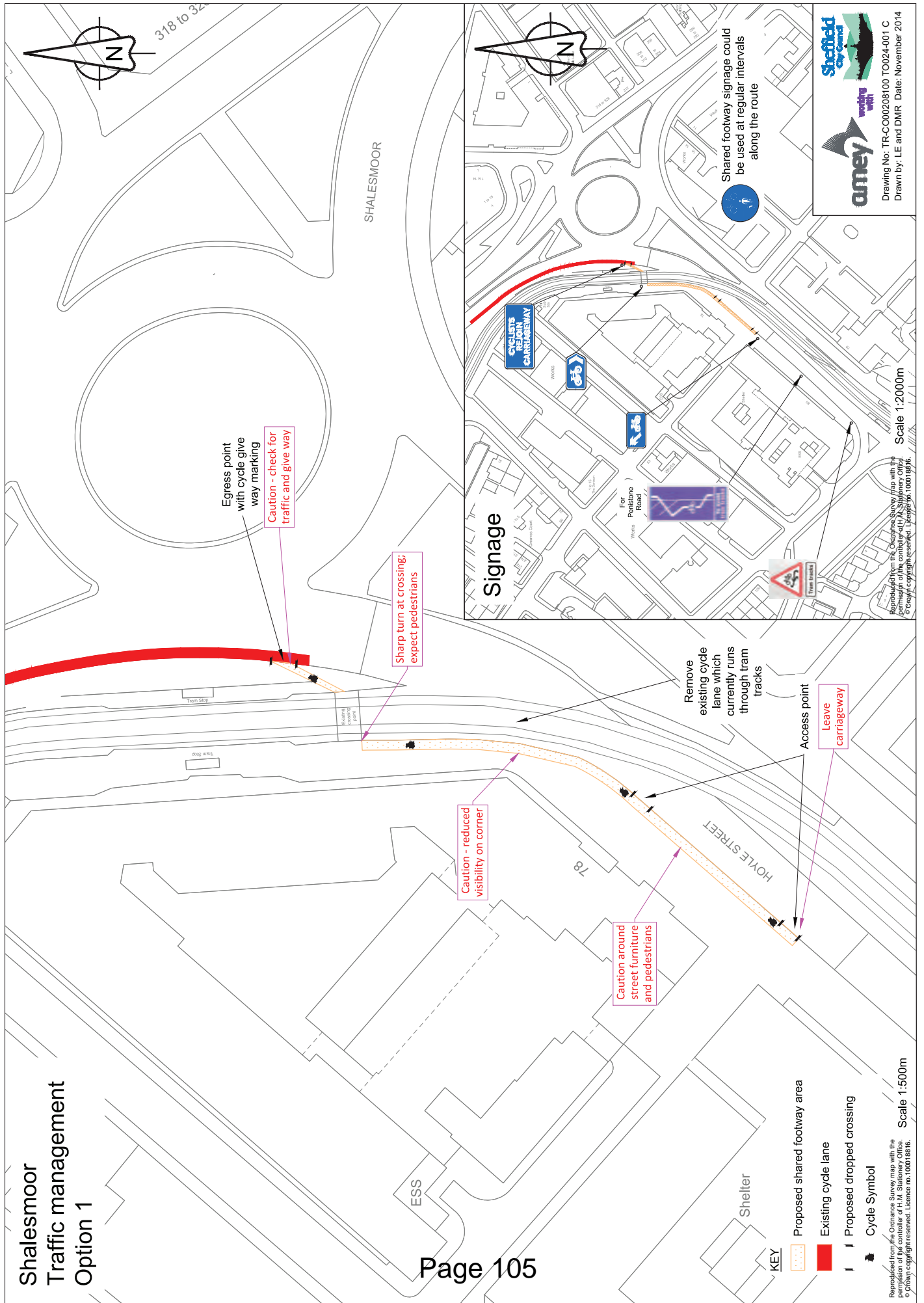
- excludes cost of Electrical Servicing, Site Preliminaries, Traffic Management and Statutory Undertakers diversions, if required

### Works in small areas

- rates for red surface treatments and other materials may increase significantly from these values if only laid in small areas on a scheme



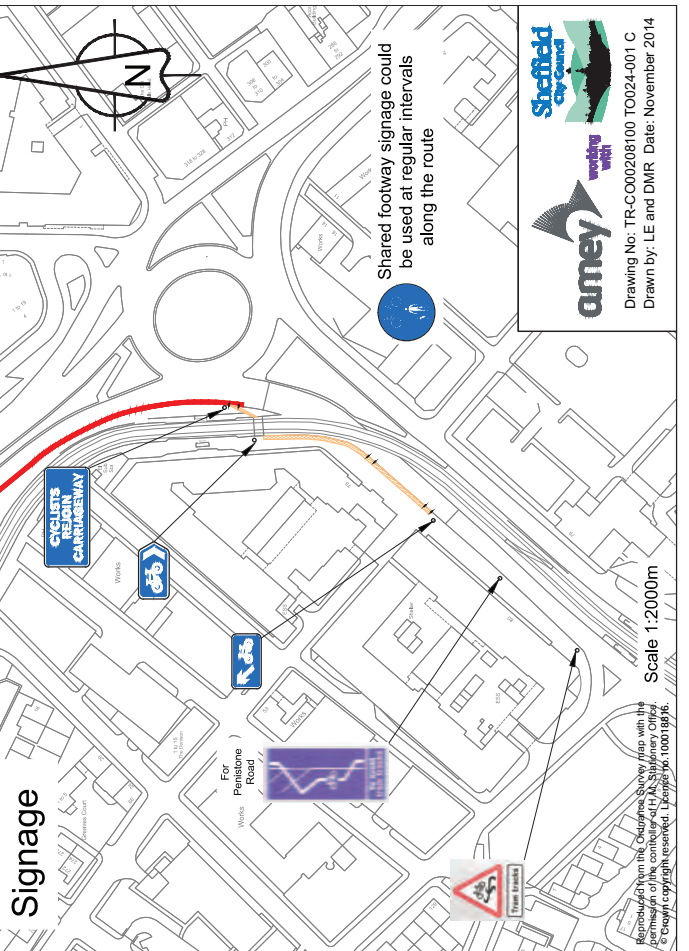
# Shalesmoor Traffic management Option 1



- KEY**
- Proposed shared footway area
  - Existing cycle lane
  - Proposed dropped crossing
  - Cycle Symbol

Scale 1:500m

## Signage



Scale 1:2000m




Drawing No: TR-CO00208100 T0024-001 C  
 Drawn by: LE and DMR Date: November 2014

Reproduced from the Ordnance Survey map with the permission of the controller of H.M. Stationery Office. © Crown Copyright Reserved. Licence no. 100018416.

# Shalesmoor Traffic management Option 2



Relevant signage to  
advise the turning  
channel in advance and  
at the point of turning

Crossing at 70°  
to tram tracks

Leave  
carriageway

Wait for signal,  
then cross



Rejoin  
carriageway  
Crossing to be  
assisted by  
existing traffic  
signals and new  
cycle signal

Remove  
existing cycle  
lane which  
currently runs  
through tram  
tracks

- KEY**
- Proposed cycle area
  - Proposed cycle crossing area
  - Proposed dropped crossing
  - Cycle Symbol

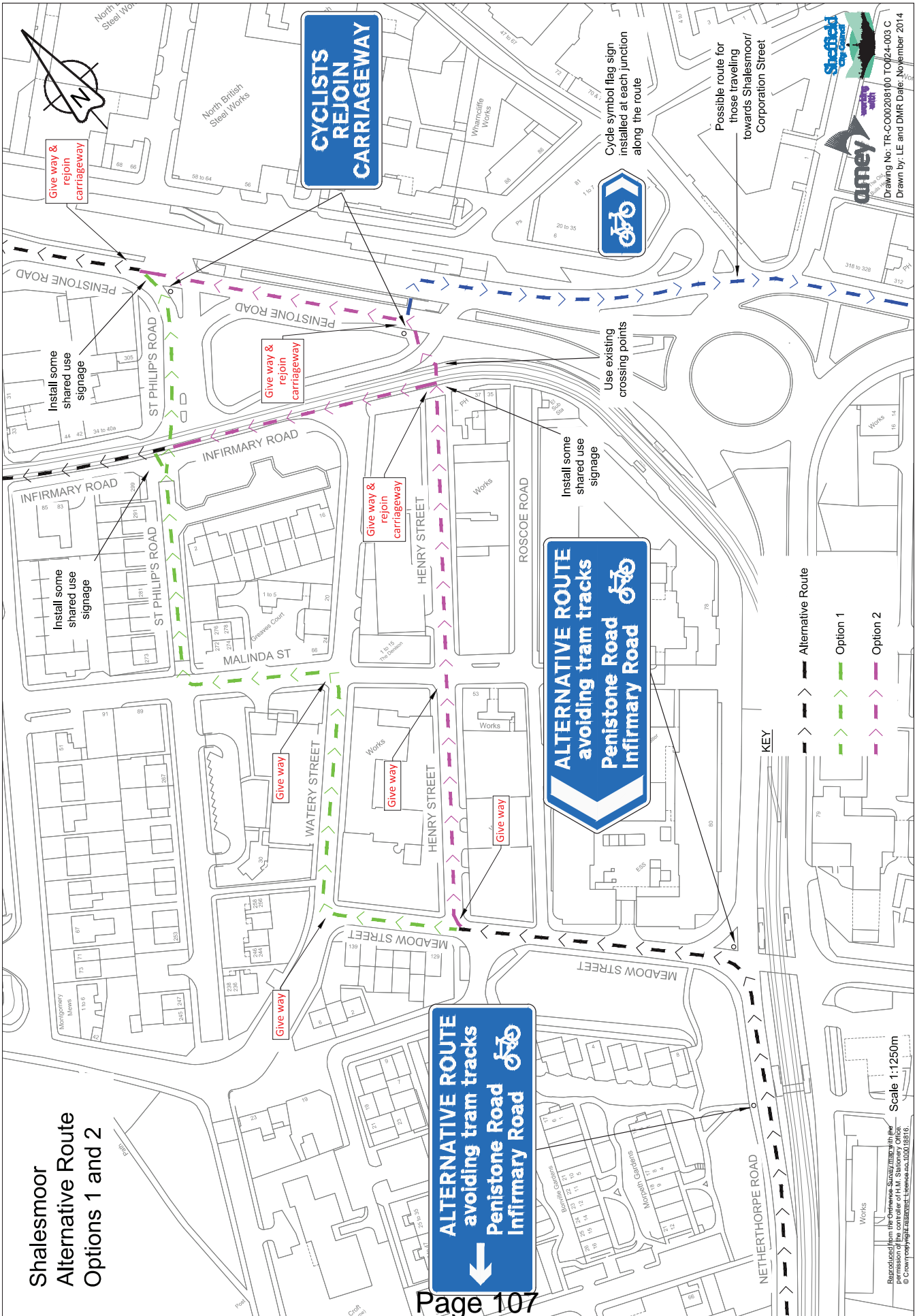
Scale 1:500m

Scale 1:200m

Reproduced from the Ordnance Survey map with the  
permission of the controller of H.M. Stationery Office,  
© Crown copyright reserved. Licence no. 1000101816.

Drawing No: TR-CO00208100 T0024-002 C  
Drawn by: LE and DMR Date: November 2014

**Shalesmoor  
Alternative Route  
Options 1 and 2**



amey  
Shalesmoor  
Drawing No: TR-CO0208100 TOJ24-003 C  
Drawn by: LE and DMR Date: November 2014

Scale 1:1250m

Reproduced from the Ordnance Survey map with the permission of the Controller of H.M. Stationery Office.  
© Crown copyright and database right 2014.

## 2. MALIN BRIDGE

Malin Bridge tram stop is located to the north west of the City Centre and is the terminus for the blue route. The area of concern is the section of tram tracks which cross the carriageway from Holme Lane to the terminus point at a 25 degree angle. There is also tram track switch work in this location which presents an additional hazard. Reported accidents at this section include cyclists who have slipped on the rails while proceeding ahead on Holme Lane going eastbound towards Middlewood Road and cyclists who have had their wheels caught in the tracks. A range of weather conditions were reported for these accidents.



### Traffic Management Proposal

#### Option 1

Option includes area of shared footway with relevant shared footway signage to create a facility for cyclists to leave the main carriageway on Loxley New Road (access road behind tram stop) to avoid the tram tracks. When re-joining the carriageway on Holme Lane, cyclists would need to give way to traffic at the signalised junction of Ball Road possibly assisted by the existing signals (cycle detection could extend inter-green periods). The shared footway area could contain some cycle symbols and some red surfacing to enhance the area if necessary and relevant shared footway signage particularly where pedestrians and cyclists interact. In addition to this some further physical works including dropped crossings would be required to provide access and egress points. It is noted that the footway is very narrow in this location for a short distance which could present problems due to pedestrian activity. Signage would include some advance direction signs, some hazard signs for cycles to warn of slippery rails and route signage to show at what point to cross the tram tracks. Department for Transport (DfT) approval would be required for some of these signs (Drawing number (Dwg No.) 004).

#### Alternative Route Proposals

These options provide an alternative route for cyclists avoiding the tram tracks on Holme Lane. Signage would direct cyclists away from Holme Lane at the Malin Bridge interchange. Repeat signage could be erected at each junction along the route. DfT approval would be required for some of these signs. (Dwg No. 005).

### **Option 1**

Route: Loxley Road to Holme Lane/Langsett Road via Dykes Lane, Harrison Road, Taplin Road and Wood Road (approx. 400m). This route is on carriageway but is difficult as it includes a significant uphill gradient. Signs and road markings would be required, but it is not envisaged that any physical work would be necessary for this route

### **Option 2**

Route: Loxley Road to Holme Lane/Langsett Road via Rivelin Valley Road, Watersmeet Road, the new shared footway, Thoresby Road and Walkley Lane/Forbes Road (approx. 900m). This route would make use of existing signage and an existing shared footway which is being constructed by the Forge Valley/Malin Bridge project. The full route would see cyclists using both shared footway and carriageway and existing toucan crossings around the Rivelin Valley junction. There is an existing dropped crossing at the end of the shared footway area on Watersmeet Road which can be utilised by cyclists to re-join the carriageway section of this route. Cycle symbols could also be placed on the shared areas. Some additional signs would be required to complement existing signage and complete the route. This route could be used in either direction. Some physical works might be required to create a dropped crossing at the end of the new shared footway on Thoresby Road if it has not already been included in the Forge Valley/Malin Bridge project. Some cycle symbols could be installed at these dropped crossings to direct cyclists along the route.

## **Cyclist Usability comments**

### **Traffic Management Proposal Option 1**

The current arrangements on site pose significant difficulties for cyclists trying to cross the tram tracks, especially due to the close spacing of the rails as they enter the terminus. This option provides an alternative route around the worst area, by directing the cyclist from Loxley New Road into the 'throat' of the Ball Road junction, thereby providing space to cross the rails at a safe angle.

There are multiple obstructions on the footway at the start of the path, as well as occasionally busy pedestrian activity to and from the nearby tram stop. The status and location of this path will need to be clearly defined. Caution will be needed at the egress point since there is potential conflict with traffic both exiting and entering Ball Road. Ideally it would be preferable to fully signalise the egress into the junction, or extend the cycle inter-green periods which could also benefit pedestrians crossing Ball Lane. Under the current proposal, cyclists would need to take care before emerging into the junction.

### **Alternative Route Proposal Option 1**

There are considerable problems with this route due to steep gradients, narrow two-way roads and parked cars. Dykes Lane is a sizeable hill with a very steep gradient at its base, certainly exceeding 10% and possibly as much as 15%. Not only does this present an inconvenience to cyclists who might wish to bypass Holme Lane, the right turn into Harrison St is located on this steep section. Cyclists will have to choose between keeping their hands on the handle bars (the leverage being essential to forward progress on such a steep gradient), or giving a clear, signal indication whilst slowing to a halt. Once on Harrison St, the cyclist is faced with a narrow, double-parked road with two-way traffic and few passing places, as is common on Hillsborough side roads. Hence there is the possibility of meeting motor vehicles coming the other way with little space or time to manoeuvre. Harrison St therefore represents problems for cyclists as a potential diversion route. It is also possible that having negotiated this part of the route, cyclists may well feel that their interests are better served by continuing along Taplin Road, and only joining the traffic and tram tracks of Holme Lane at the last possible moment (or indeed cutting through to Middlewood Rd for destinations to the North). Emerging on to Wood Road is only likely to be attractive to cyclists wanting to end their journey on the short stretch of Holme Lane between here and the Tramways centre.

## **Alternative Route Proposal Option 2**

A reasonably practical option for those travelling to the Hillsborough Barracks complex, Langsett Rd and points travelling South-East. Again there is a modest gain in height but over much shallower gradients. Although this route is away from traffic, some cyclists might have concerns over personal safety, as the route cuts between the garages at the end of Watersmeet Rd and across 200 metres of what is essentially waste ground. The route then goes via Thoresby Rd to either Walkley Lane or Forbes Rd. Cyclists choosing the latter should also be aware of bus movements in this area.

## **Road Safety comments**

Accsmap - Reported injury RTCs 1st October 2009 – 30th September 2014 (5 years)

3 x slight injury crashes – None involved pedal cyclists.

## **Traffic Management Proposal Option 1**

Problems

- The footway width adjacent to number 8 Loxley New Road is insufficient for shared use. The high numbers of pedestrians at times could result in cycle/pedestrian conflict in the vicinity of the pedestrian tactile crossings.
- Conflict with other traffic at the egress point at Ball Road. A lot of junction blocking occurs at this junction particularly at peak periods.
- As a result of the junction blocking vehicles are regularly observed to travel through the junction when the traffic signals are at red – a cyclist may not be expecting traffic from that particular direction.
- Risk of cyclists re-joining Holme Lane at shallow angle across the tram tracks, which would require positive signage to assist cyclists to adopt the correct course.

Advantages

- Provides a parallel route, it is intuitive and avoids the interlaced track at this location.

## **Alternative Route Proposal Option 1**

Problems

- Uphill gradient at Dykes Lane may discourage use especially by the less able cyclist.
- Conflict turning right at very low speed, potentially unstable, onto Harrison Road from Dykes Lane.
- Historic collision problem at Taplin Road with junction overshoots at the Ball and Wood Road junctions. (Although these appear to have drastically reduced since the traffic calming and plateaus were installed).
- Wood Road junction with Holme Lane may need positive markings to direct cyclist to adopt correct course across tracks.

Advantages

- Provides an alternative route avoiding the problem area.

## Alternative Route Proposal Option 2

### Problems

- A convoluted route that may be unattractive for cyclists and therefore overlooked/underused.
- Footway widths at Loxley Road and Holme Lane (between Rivelin Valley Road and Loxley New Road) appear to be sub-standard widths for shared use.
- A pinch point at the Loxley Road junction outside the off licence will create pedestrian / cycle conflicts.
- The footways all have heavy pedestrian use, particularly around school start/finish and lunchtimes.
- The proposed section of new shared footpath, linking Watersmeet Road and Thoresby Road, would require significant widening/upgrade to remove conflicts with pedestrians and improve inter-visibility at the start and finish points.
- The route ends at the eastern section where cyclists wishing to travel to Hillsborough Corner are faced with a compulsory left turn (away from their destination) at the Walkley Lane / Holme Lane junction.
- Those cyclists choosing to use Forbes Road to reach Langsett Road and Hillsborough Corner are faced with a compulsory right turn (away from their destination).

### Advantages

- Unless suitable additional facilities are provided to take cyclists back to their original route, Road Safety would not support this option.

## MALIN BRIDGE - Budget Estimates

Traffic Management Proposals	Estimate
<b>Option 1</b>	
Cycle Crossing o/s 8 Loxley New Road	£3100
Traffic Signs and Lines	£1500
Cycle Detection & Signal configuration	£3500
<b>TOTAL:</b>	<b>£8100</b>

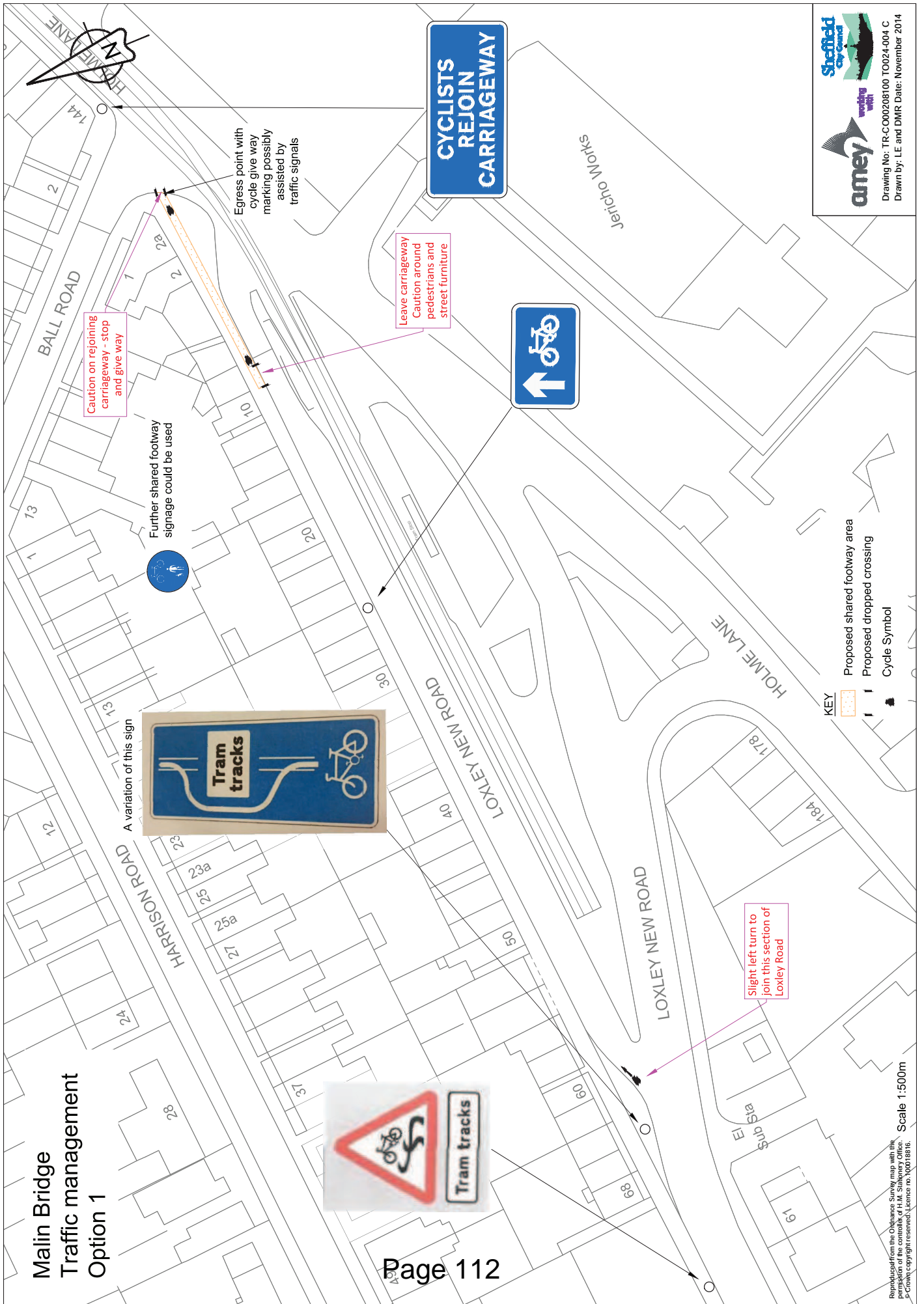
Alternative Route Proposals	Estimate
<b>Option 1</b>	
Traffic Signs and Lines only	<b>£1100</b>
<b>Option 2</b>	
Traffic Signs and Lines only ( <b>excludes</b> any widening of footways, if required)	<b>£1600</b>




## Notes

### Construction costs estimate only

- excludes cost of Electrical Servicing, Site Preliminaries, Traffic Management and Statutory Undertakers diversions, if required

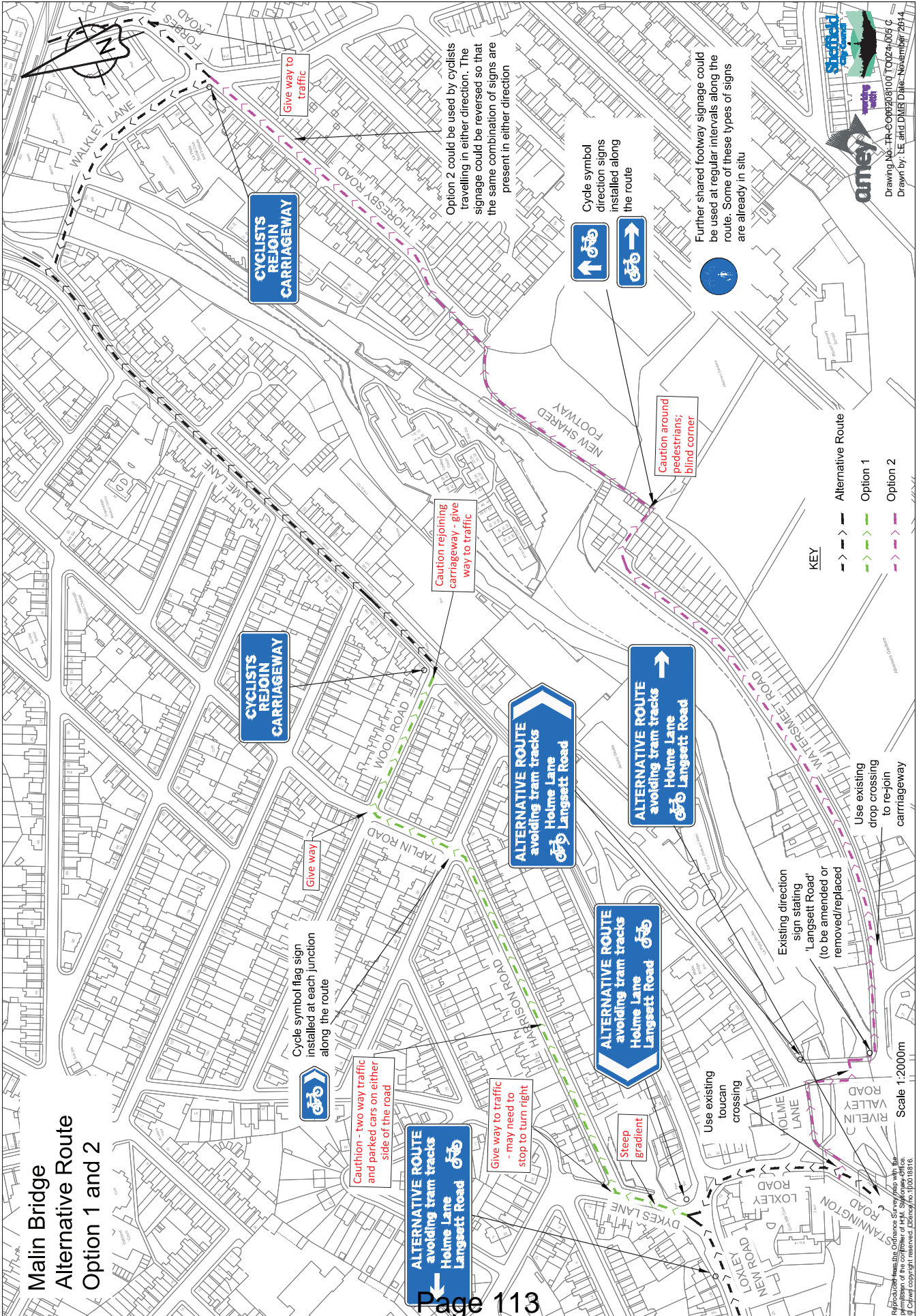
**Malin Bridge  
Traffic management  
Option 1**



- KEY**
-  Proposed shared footway area
  -  Proposed dropped crossing
  -  Cycle Symbol



**Malin Bridge  
Alternative Route  
Option 1 and 2**



### 3. CITY ROAD / PARK GRANGE ROAD

The City Road / Park Grange Road junction is located to the south east of the City Centre. Trams using the track at this junction are part of the blue and purple routes linking the Gleadless Town area of Sheffield with the City Centre. The area of concern is the section of tram tracks which cross the carriageway from City Road to Park Grange Road at a 25 degree angle. Reported accidents at this section include cyclists who have slipped on the rails while proceeding ahead from City Road towards Duke Street. The conditions at these accidents were reported as wet.



#### Traffic Management Proposals

##### Option 1

This option includes area of cycle lane on City Road going towards the City Centre. The cycle lane is proposed to give cyclists guidance across the tram tracks and to push traffic away from a cyclist's line of travel to give the cyclists more room to cross the tram tracks (possibly at a particular angle). The cycle lanes should include new road markings and possibly coloured surfacing. (Drawing no 006).

##### Option 2

This option includes an area of shared footway with relevant shared footway signage to create a facility for cyclists to leave the main carriageway to avoid the tram tracks. Cyclists would re-join the carriageway after the junction of City Road/Park Grange Road. Some street furniture would need to be moved to implement the shared footway. The shared footway area could contain some cycle symbols and some red surfacing. In addition to this, some physical works including dropped crossings would be required to provide access and egress points. Signage would include hazard warning signs and route signage. Department for Transport (DfT) approval would be required for some of these signs (Drawing no 007).

## **Alternative Route Proposals**

### **Option 1**

Route: City Road to City Road avoiding tram tracks via Craddock Road, Brimmesfield Road, Spring Lane, Park Grange Road and St Aidan's Road (approx. 1500m). This route uses signed and advisory routes on the Sheffield Cycle Network. Some physical work features would be required at either end of the route to create access and egress points for cyclists to re-join the main carriageway. Some cycle symbols could be included at the dropped crossing areas. Some additional signage would be required to tie into the existing routes. (Dwg no. 008 (1)).

### **Option 2**

City Road to City Road avoiding tram tracks via Craddock Road, existing playing field and footways (approx. 600m). This route is shorter than option 1 and avoids the incline on Craddock Road. The route takes cyclists off Craddock Road and through existing playing fields and footways back to City Road. Some land will need to be acquired, new cycle ways installed and existing footways upgraded for shared use. Some additional signage would be required to tie into the existing routes. (Dwg no. 008 (1)).

## **Cyclist Usability comments**

### **Traffic Management Proposal Option 1**

The intention here is for cyclists to make a partial left turn into a marked refuge on the corner of Park Grange Road, then to move right across one pair of tram tracks, re-joining a marked cycle lane on the main carriageway. This option has the advantage of simplicity and potentially involves the least delay/inconvenience to the cyclist. However there are several disadvantages to the layout as proposed:

If approached 'sight unseen' and with a degree of caution, the cyclist is likely to come to a dead halt in the marked refuge. They must then turn the bicycle through 90 degrees and wait for a gap in both left-turning traffic (so they can set off) and City Road traffic (so they may then move into the marked cycle lane and continue down City Road).

On a related note, the presence of a trief-kerbed traffic island 10m or so down the main road will tend to force traffic over to the left where it is likely to encroach into the cycle lane. This might be an issue adjacent to the island itself but at the point where the cyclist is expected to join the marked cycle lane, traffic will already be moving over. It is therefore unrealistic to expect the cycle lane to be left clear, resulting in the need to wait for a gap.

If, in the time between turning off City Road and reaching the marked cycle lane, the lights have changed in favour of traffic from Park Grange Road, the cyclist will be placed in conflict with that traffic and, worse, might not be aware of this.

Given some prior experience of the proposed layout, cyclists might overcome some of these difficulties by giving a right-hand signal as they start to bear left. At best this will illustrate their intention to carry on down City Rd; at worst the driver might wonder what manoeuvre the cyclist is planning and at least hang back. Either way, the cyclist will then be free to bear left, and then swing right across the cycle tracks in one smooth movement. This manoeuvre will take much less time than the 'stop-cross-re-join' option and so, apart from causing less delay, is less likely to leave the cyclist stranded between the different parts of this facility. Also, because they have maintained their position in front of the following vehicle, it is far less likely to try and overtake and then cut in before the trief-kerbed island as there wouldn't be time to initiate an overtaking manoeuvre from that position. Admittedly this approach does carry some risk of a motorist turning left regardless of the above, but this can be minimised by shoulder-checking, signalling early, making eye contact if possible and maintaining a clear signal throughout.

## **Traffic Management Proposal Option 2**

Here cyclists have the option of leaving the road just before the stop line and continuing on a segregated path on the footway. This leads them slightly further round the corner than in Option 1, to an uncontrolled pedestrian crossing. They will then cross both tram tracks and the left-hand filter lane before joining another segregated path, which directs them to re-join the carriageway 20 to 30m further on. The main disadvantage to this layout concerns available space and the positioning of street furniture. There is currently a signal pole in the middle of the first path as well as two further sign posts in the second path, which would need to be re-located. It is likely to be preferable to create shared cycle/footways rather than a separate cycle path alongside a footway area. It is also possible that the second cycle path need not be provided as cyclists could simply re-join the carriageway directly from the left-hand filter lane with no significant increase in risk.

## **Alternative Route Proposal Option 1**

In order to avoid the junction altogether, cyclists are directed up Craddock Rd, right onto Bimmesfield Rd, right again onto Spring Lane, across Park Grange Rd and onto St. Aidan's Rd, eventually emerging approximately 1km further down City Rd. The main disadvantage of this route is its convoluted nature – it takes in a fairly steep climb, two potentially awkward right-hand turns, a main road crossing and adds nearly 600 metres to the cyclist's journey. As with the Harrison Road diversion at Malin Bridge, it seems like a route one would only use if it were the only choice. In practice, the less able cyclist would lose less time by crossing the Park Grange Rd junction as a pedestrian, then remounting. However, it is a quiet and reasonably safe route for those who prefer to stay away from main roads and who would prioritise that over outright speed. It might also be a useful cycle route for some other destinations.

## **Alternative Route Proposal Option 2**

This route is derived from Option 3 but is considerably shorter and without the 10 to 15 metre climb up Craddock Rd. Cyclists would instead turn right into the park after 50m, crossing the park (could a gravel path be provided around the perimeter?) and emerging onto Spring Lane tram stop, where it would be advisable to dismount and use the pedestrian crossing. They could then follow the local footpaths (could these be upgraded to mixed-use?), re-joining the now tramline-free City Road at the first opportunity adjacent to No. 536. This route involves much less of a diversion, taking 570m to cover a straight-line distance of 410 (by comparison, Option 3 takes 1570m to cover a straight-line distance of 1000). To work at its best it would however require significant physical works (though it could be argued that a path through the park would be a benefit to all).

## **Road Safety comments**

Accsmap - Reported injury RTCs 1st October 2009 – 30th September 2014 (5 years)

2 x slight injury crashes – One involved a pedal cyclist who collided with a van on the north-west bound approach to the junction.

## **Traffic Management Proposal Option 1**

Problems

- The right turn cycle lane within the hatched area requires cyclists to travel, albeit marginally, against the direction of oncoming traffic. Risk of head on or side swipe collisions.
- This right turn arrangement appears to conflict with the pedestrian crossing lowered kerbs.

- New Cycle markings may be a skid hazard to other road users and particularly powered two wheelers.
- A pedal cyclist may be stranded within the nearside swept path of a turning tram whilst trying to join the cycle lane across the junction mouth.
- Once a cyclist enters the cycle lane they are unaware of the traffic signal stage and therefore may be part way across the junction and confronted by traffic emerging from Park Grange Road.
- The carriageway width at the central island on City Road may create a conflict with vehicles trying to squeeze past cyclists in the advisory cycle lane.
- It appears that cyclists are required to cross the 'outbound' rails at a shallower angle than that desired.

#### Advantages

- Cyclists choosing to use the facility have an opportunity to cross 'inbound' rails at right angles. (Although there is a risk of collision with following traffic)

### **Traffic Management Proposal Option 2**

#### Problems

- Conflict with pedestrians sharing the same crossing points.
- Insufficient footway width for shared use. (3.5mts required on the footway and 3.0mts at the splitter islands)
- Inter-visibility (pedestrians/cycles) outside number 604 City Road.
- The southern dropped tactile kerb at Park Grange Road directs pedestrians to cross at a point where the view of oncoming left turning traffic from City Road is limited. This is an existing conflict and would require improvement.

#### Advantages

- This provides cyclists with a route that crosses both pairs of rails at the required angle.
- If visibility and footway widths could be improved it appears to be the most logical resolution of the traffic management options.

### **Alternative Routes**

Accsmap - Reported injury RTCs 1st October 2009 – 30th September 2014 (5 years)

4 x slight injury crashes were recorded on the alternative route – Two involved pedal cyclists one at the City Road/Craddock Road junction and one at Spring Lane.

#### **Alternative Route Proposal Options**

- Convoluted route that may be unattractive for cyclists and therefore overlooked/underused by them.
- Crossing at the Spring Lane junction of Park Grange Road would involve upgrade of footways to shared use; otherwise cyclists would be running alongside the tram route (head on) until they reach the St Aidans Road junction.
- Involves contra-flow cycling on a section of St Aidans Road, unless this was to be on a shared use basis as above.

## Advantages

- Connects to existing signed cycle routes.
- Provides an alternative route for less confident cyclists.

## City Rd / Park Grange Rd - Budget Estimates

### Traffic Management Proposals

Estimate

#### Option 1

Traffic Signs and Lines **£500**

#### Option 2

Cycle Crossing off City Road £3100

Cycle Crossing on City Road £3100

Traffic Signs and Lines £2100

**TOTAL: £8300**

### Alternative Route Proposals

Estimate

#### Option 1

Traffic Signs and Lines **£1500**

#### Option 2

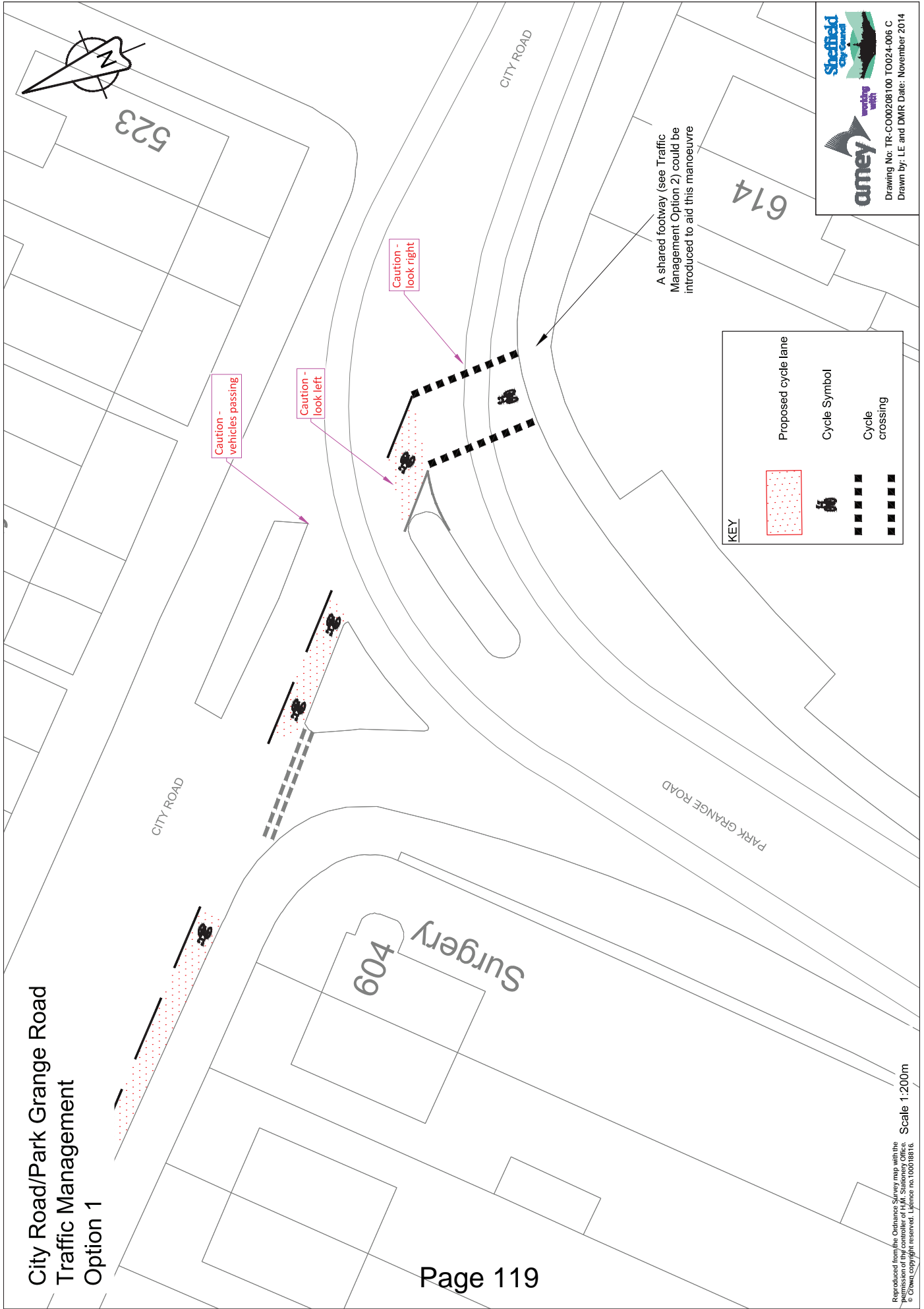
Traffic Signs and Lines **£1500**

New Cycle Track – including land acquisition) not Known

*NOTE: there are **significant** additional costs for this scheme – for land acquisition and construction of a new cycle track – which it has not been possible to estimate without further investigation. This proposal would need support in principle to progress before it would be considered worthwhile carrying out this additional preliminary work.*

*Construction costs estimate only – excludes cost of Electrical Servicing, Site Preliminaries, Traffic Management and Statutory Undertakers diversions, if required*

City Road/Park Grange Road  
Traffic Management  
Option 1





  
 Drawing No: TR-CO00208100 TO024-006 C  
 Drawn by: LE and DMR Date: November 2014

# City Road/Park Grange Road Traffic Management Option 2

Caution - re-join  
carriageway

CITY ROAD

604  
Surgery

**CYCLISTS  
REJOIN  
CARRIAGEWAY**

Page 120

PARK GRANGE ROAD

523

Shared footway signage  
could be used at regular  
intervals along the route  
Route signage could be  
used at each crossing  
point along the route



**KEY**

- Proposed shared footway area
- Proposed dropped crossing
- Cycle symbol
- Route across existing crossings

Wait for signal  
and cross

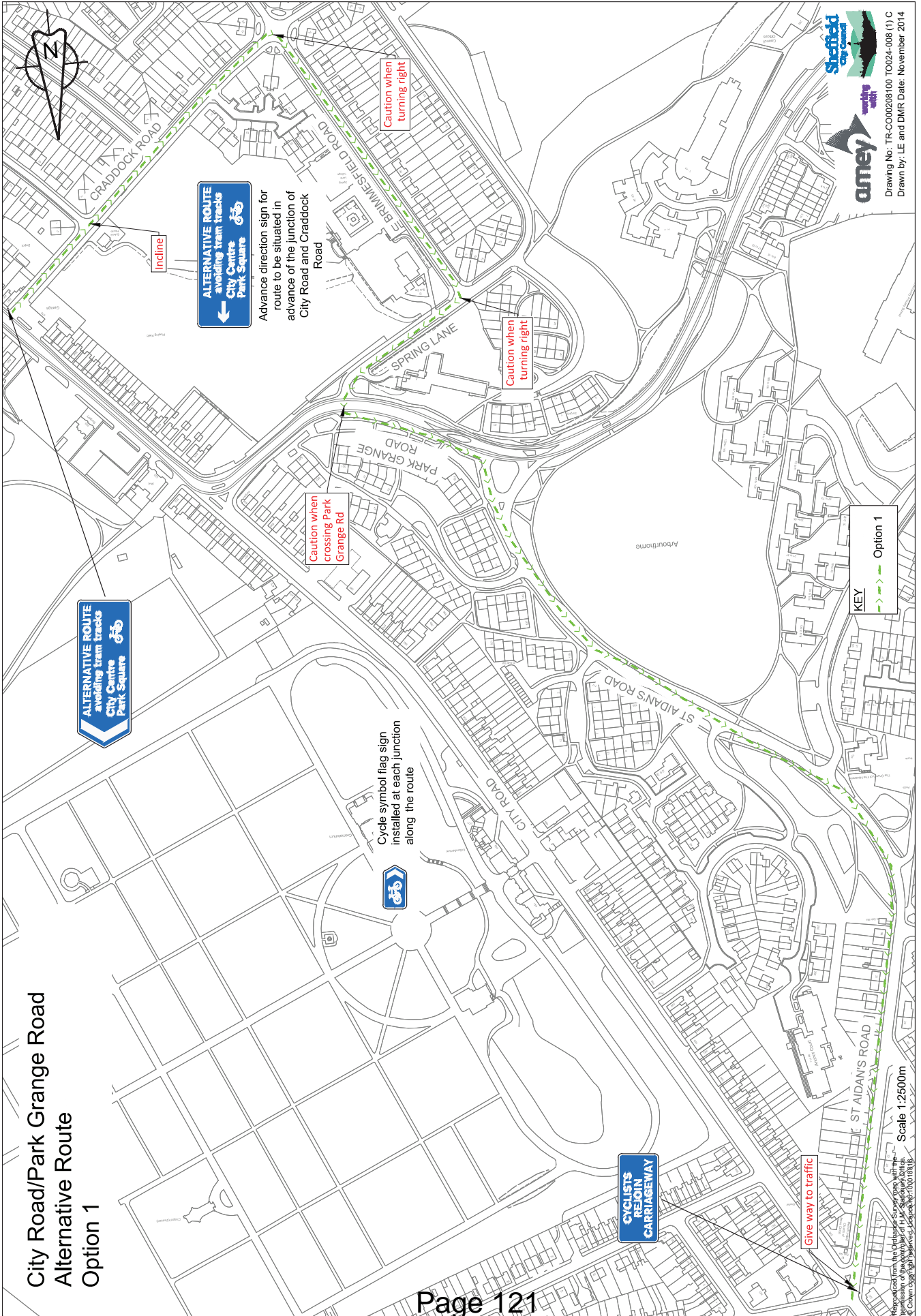
Wait for signal  
and cross



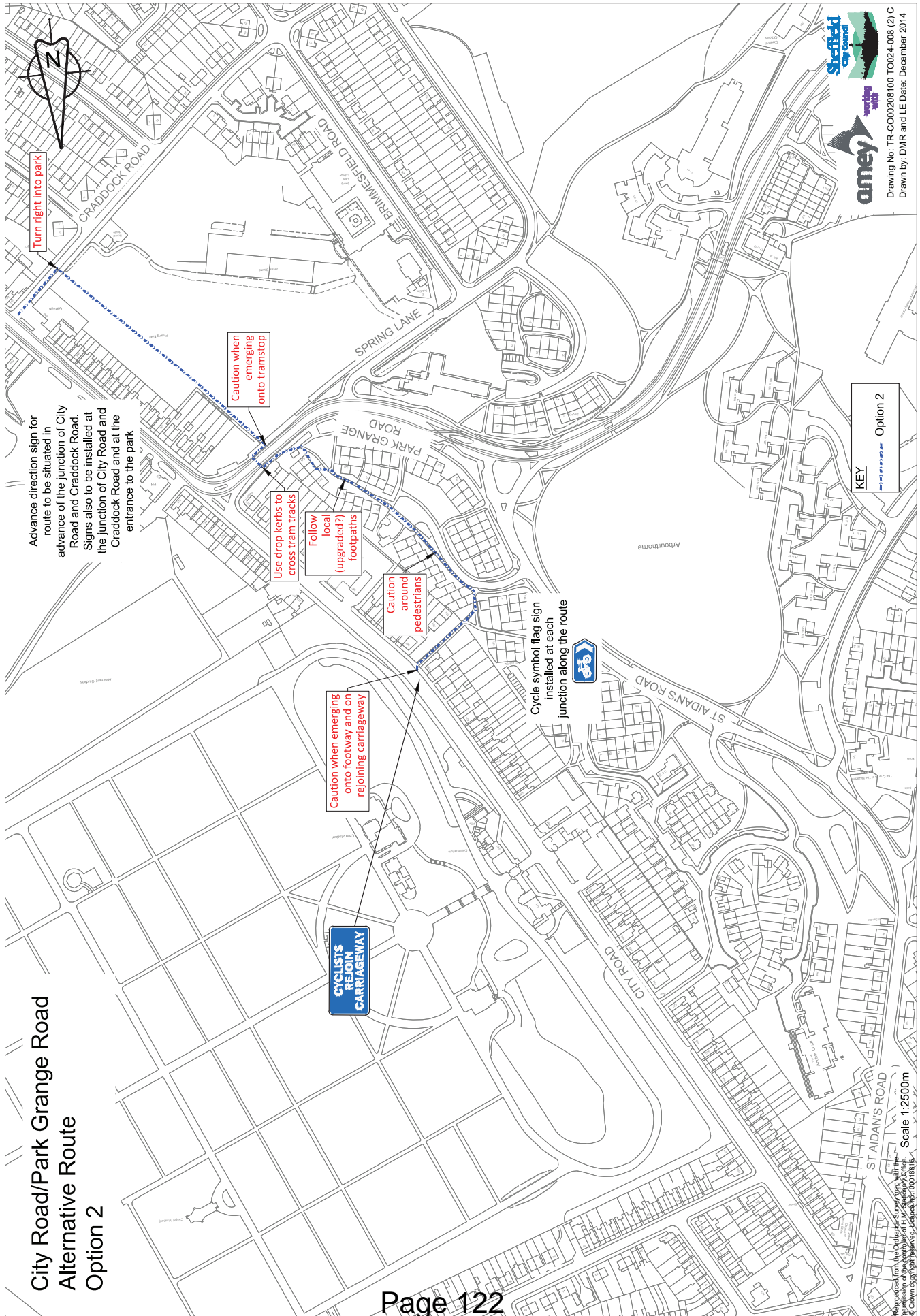
amey walking with Sheffield City Council  
Drawing No: TR-CO00208100 TO024-007 C  
Drawn by: LE and DMR Date: November 2014



**City Road/Park Grange Road  
Alternative Route  
Option 1**



**City Road/Park Grange Road  
Alternative Route  
Option 2**



#### 4. TRAM STOPS on LANGSETT ROAD

Primrose View tram stop is located on Langsett Road. It is part of blue and yellow routes which link the City Centre to Malin Bridge and Middlewood Road to the north west of Sheffield. The area of concern is the interaction between the tram stop build outs and the way in which cyclists pass them particularly if they are riding at the kerbside. Reported accidents include cyclists that have slipped on the rails and also got caught in the tracks. A range of weather conditions were reported for these accidents.



#### Proposals

##### Option 1

This option includes extending the existing cycle way that runs alongside Langsett Road past the Primrose View tram stop. This would include some new shared footway near Burgoyne Road. Some physical work will be required to widen the existing footpaths. An area of cycle way would then begin at the junction of Primrose Hill and Langsett Road. The cycle way would go behind the tram stop on the existing grass bank. Some physical works would need to take place here to level the bank or a retaining wall may be necessary. Consideration would also need to be given to the location of existing trees, statutory undertaker assets (i.e. BT cabinets) and street furniture and whether any would need to be moved. Dropped crossings would need to be installed at each junction along the route and some existing tactile crossings may need to be modified. The shared footway area and cycle way could contain some cycle markings and some red surfacing to improve visibility of the facility. Some shared cycle/footway signage could also be used at regular intervals along the route (Drawing number 009). It is acknowledged that some of the first part of the proposed cycle/footway is below current recommended widths, so some investigation of whether this could be improved would be required.

##### Option 2

This proposal is a possibly extreme case of how new cycle road markings could be used to guide cyclists to cross the tram tracks on approaching and passing a tram stop. The works provide a shared cycle/footway area for cyclists to leave the carriageway and re-enter so that they cross the tram tracks at close to 90 degrees in several locations. The facilities and road markings would allow less able

cyclists to stop in several places and only proceed into each area if the way ahead is clear. Some physical works would be required to install dropped crossings at relevant access and egress points along the route (Dwg No. 010)

It is recognised that use of some of these waymarked routes on-street could be problematic unless cyclists check to see that the way is sufficiently clear before progressing along them. Specific signing related to this might be necessary if this type of scheme were to be progressed.

NOTE: similar treatments may be possible at some other tram stops along the tram route.

## **Cyclist Usability comments**

### **Option 1**

#### **Hillsborough (Outbound) direction**

Footway between Whitehouse Rd and Burgoyne Rd is very narrow, particularly outside the 'pinch point' South of no.71. The usable width of this section appears to be less than 2 metres for most of its length due to the presence of lighting columns and Supertram overhead poles. If acceptable to use, it may therefore be necessary to provide signage warning both cyclists and pedestrians of the hazards in this section. Cyclists would then need to cross Burgoyne Rd, a side road with light traffic flows, before crossing Primrose Hill which is a quiet cul-de sac. At both locations, cyclists would need to check for traffic in all directions before crossing.

The proposed off-road cycle path would then cross two small footpaths leading to the tram and bus stop, where conflicts with pedestrians could arise so that cyclists need to ride with caution. Tactile paving could be used to indicate these crossing points.

The first egress on to carriageway between the tram stop and bus stop might be problematic, so that re-locating this into the bus layby might be preferable, as this is normally unoccupied, to allow cyclists more space and time to emerge on-street. Cyclists would also need to exercise caution at the second egress point at the junction of Normandale Rd.

If funding permits, extending this cycle track further along this section behind and beyond the Bamforth St tram stop to Channing St might also be worthwhile

#### **Upperthorpe (Inbound) direction:**

This is a short bypass facility allowing cyclists to leave the road just after Jeff Hall motorcycles and re-join immediately after the tram stop. However, on exit it might be preferable to direct cyclists into the bus layby so that they have more space and time to re-join the main flow of traffic.

### **Option 2**

#### **Hillsborough (Outbound) direction**

Cyclists need to ride cautiously when crossing the junction with Primrose Hill as for Option 1. The next section could be problematic as cyclists must wait for a gap in the traffic in order to cross to the centre, where they must turn sharply and ride to the right of the right hand rail for 65 metres to the relative safety of the chevrons, where they may have to wait once again for a gap in order to cross, remount and re-join the traffic flow. Assuming their speed to be around 5m/s, they would be out in the far right of the lane for around 13 seconds, with a good chance of faster traffic catching up in the meantime. It is likely that any cyclist confident enough to do this would probably prefer the uninterrupted route between the rails, at least for long enough to clear the tram stop.

### **Upperthorpe (Inbound) direction:**

The same general comments apply as for the Outbound direction, except that the time spent in the 'outer zone' is even longer - 100 metres or around 20 seconds! An alternative to the turning loop by Ash St might be to use the mouth of the junction as this is one-way away from Langsett Rd. once is verified that no traffic is turning off Langsett Rd into this road.

The viability of these two on-street facilities could therefore be problematic.

### **Road Safety comments**

Accsmap - Reported injury RTCs 1st October 2009 – 30th September 2014 (5 years)

3 x slight injury crashes – none involving pedal cycles.

#### **Option 1**

##### Problems

- Insufficient footway widths between Whitehouse Lane and Primrose Hill. 3.5metres is required with not much scope to increase the width.
- Inter-visibility between pedestrians and cyclists at the Primrose Hill junction/ interface with tactile paving from pedestrian crossing.
- Egress point to carriageway at the end of 'outbound' tram stop – conflict with pedestrians and vehicles.
- Normandale Road at the egress may be significant conflict with vehicles turning into the junction from Langsett Road.
- Egress point at the 'inbound' tram stop is a conflict, adjacent to central island. It may be preferable to relocate the egress to the entry taper at the bus lay-by.

##### Advantages

- It is a direct parallel route that is likely to be well used by many cyclists.
- If there is insufficient width for shared use footways in the first section, then the route could commence at Primrose Hill which would still achieve the scheme objectives.

#### **Option 2**

##### Problems

- The pedal cyclist is weaving onto and off the footway and across the carriageway, this introduces multiple conflict points
- New cycle road markings might be a skid hazard to other road users particularly powered two wheelers.
- Directs cyclists to run directly alongside central islands so they are likely to be squeezed by passing vehicles (drivers are likely to undertake them if possible) and may strike the kerb.
- Cyclists are positively directed to ride into the hatched areas – these are so marked to separate traffic flows likely to be a danger to one another. This might increase the risk of head on collisions.
- Shared footway width is insufficient (as per option 1)
- Inter-visibility at Ash Street - conflict with pedestrians and vehicles.
- Use of the existing pedestrian crossing points may conflict with pedestrians using this facility.

##### Advantages

- The road safety problems outweigh any potential benefits that this option may provide.

Road Safety considers option one to be safer, although the identified problems would need to be addressed. This provides the most benefit for cyclists who are less confident of riding 'with the tram tracks' and is also likely to be used by the more confident cyclist. It provides a link and extension to the existing well-established cycle route, if the footway width issue can be addressed between Whitehouse Lane and Primrose Hill.

## TRAM STOPS on LANGSETT ROAD - Budget Estimates

### Traffic Management Proposals Estimate

#### Option 1

##### Out bound carriageway

3 No. Cycle Crossings on/off shared use footway	£ 9600
3 No. Cycle Crossings on/off new footway	£ 5400
Hazard Warning paving	£ 2800
New cycle way	£ 27000
Re-grading works	£ 15000
Traffic Signs and Lines	£ 800
<b>TOTAL:</b>	<b>£60600</b>

##### In bound carriageway

2 No. Cycle Crossings on/off new footway	£ 6400
New cycle way	£ 5000
Traffic Signs and Lines	£ 800
<b>TOTAL:</b>	<b>£12200</b>

#### Option 2

##### Outbound carriageway

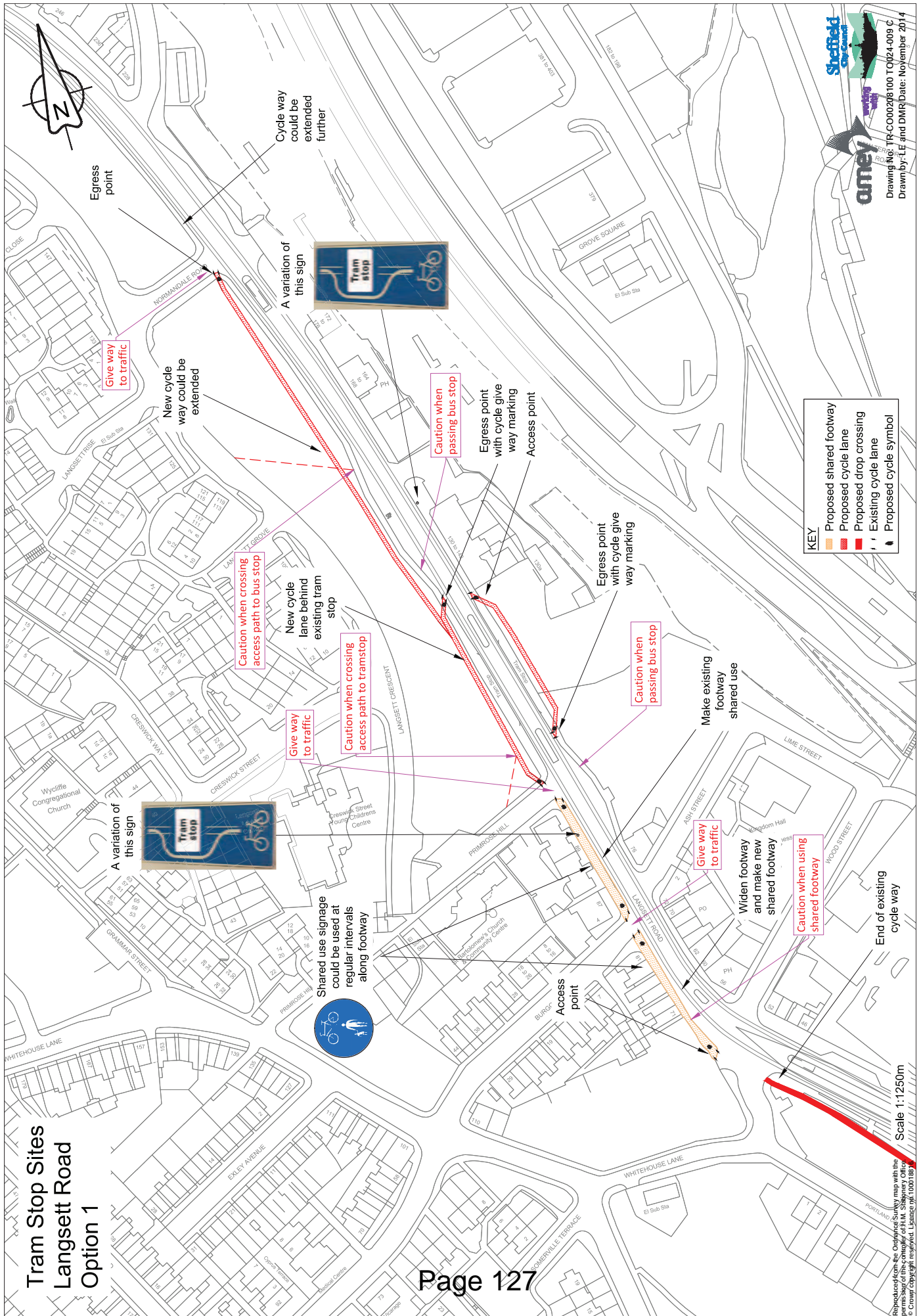
5 No. Cycle Crossing on/off shared use footway	£16000
Traffic Signs and Lines	£1000
<b>TOTAL:</b>	<b>£17000</b>

##### Inbound carriageway

3 No. Cycle Crossing on/off shared use footway	£ 9600
Traffic Signs and Lines	£1000
<b>TOTAL:</b>	<b>£10600</b>

*Construction costs estimate only – excludes cost of Electrical Servicing, Site Preliminaries, Traffic Management and Statutory Undertakers diversions, if required*

# Tram Stop Sites Langsett Road Option 1

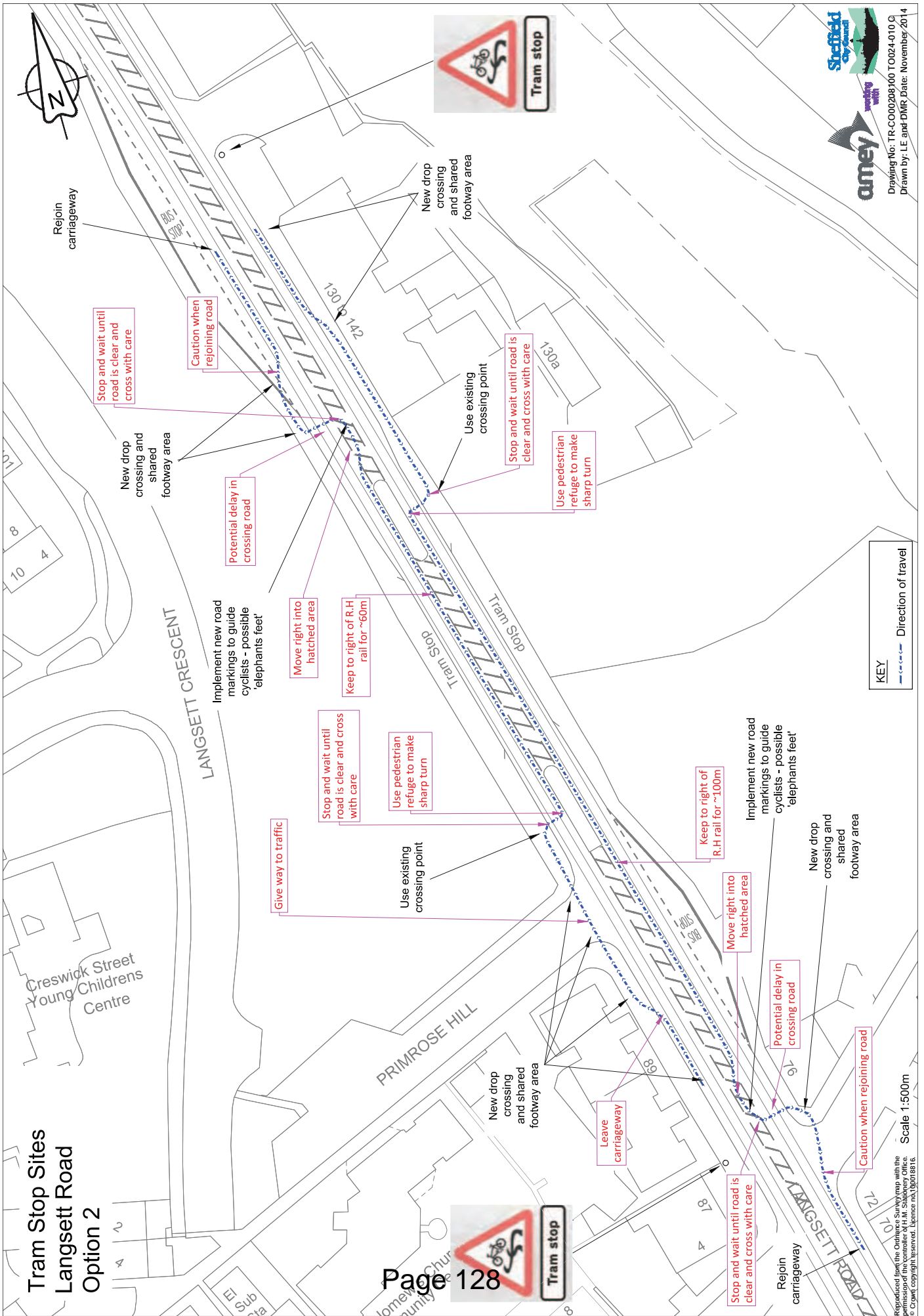


**KEY**

- Proposed shared footway
- Proposed cycle lane
- Proposed drop crossing
- Existing cycle lane
- Proposed cycle symbol

Reproduced from the Ordnance Survey map with the permission of the controller of H.M. Stationery Office. Crown Copyright. Licence No. 10001292

# Tram Stop Sites Langsett Road Option 2





## 5. PARK GRANGE CROFT

The Park Grange Croft tram stop is to the south east of the City Centre. Trams using the track at this stop are part of the blue and purple routes linking the Gleadless Town area of Sheffield with the City Centre. The area of concern is the section of tram tracks which cross the carriageway from Park Grange Road to the tram stop at a 35 degree angle. There is currently no accident data available for this location.



### Traffic Management Proposals

#### Option 1

This option provides a new cycle way taking cyclists off the main carriageway and behind the existing tram tracks. Some physical works would need to take place to create the cycle way through the existing grass bank. A retaining wall or re-grading works may be required and some existing street furniture may need to be moved. Other works would include new dropped crossings and an area of shared footway with relevant shared footway signage. The shared footway area could contain some cycle markings and some red surfacing to enhance the area if necessary. Crossing the access to Queens Gardens could be indicated using new cycle road markings. It is not envisaged that this would be assisted by traffic signals as traffic levels at this location are low. Cyclists would then re-join the carriageway via an existing crossing point. Signage would include hazard warning signs and route signage. Department for Transport (DfT) approval would be required for some of these signs (Drawing number (Dwg no.) 011).

#### Option 2

This option provides a cycle lane on Park Grange Road which leads onto a section of off-highway cycle way. Crossing the access to Queens Gardens could be shown using new cycle road markings. The cycle facilities are proposed to give cyclists guidance across the tram tracks and to take cyclists

away from traffic when crossing the tracks. The cycle lane will include cycle symbols. Red surfacing could also be laid to enhance the lanes (Dwg no. 012).

## **Alternative Route Proposals**

This option includes an alternative route for cyclists avoiding the tram tracks on Park Grange Road in this area. The route would use some minor roads and footways. Some of the footways may need to be converted for shared use. Signage would direct cyclists away from Park Grange Road onto the alternative route. DfT approval would be required for some of these signs (Dwg no. 13)

### **Option 1**

Route: Park Grange Road to Park Grange Road avoiding tram tracks at Park Grange Croft via Park Spring Drive, Frank Wright Close and existing footpath behind Queens Gardens (approx. 400m). Some physical work features would be required at either end of the route to create access and egress points for cyclists to re-join the main carriageway. Some street lighting work may also be required to ensure that the existing footpath behind Queens Gardens is adequately lit for safety reasons. Some cycle symbols could be included at the dropped crossing areas.

## **Cyclist Usability comments**

### **Traffic Management Proposal Option 1**

An off-road path, cut through an embankment, crossing the access road to Queen's Gardens and turning to cross the tram tracks at 90° before re-joining the carriageway. Cyclists leave the carriageway approx. 45m before the junction, and are given priority over this junction by means of new 'Give Way' markings to the Queen's Gardens access road. It would still be advisable to cross this road with caution and keep to sensible speeds. The existing footway is converted to shared use, allowing cyclists to cross the tracks at a safe angle and with good visibility. The path then ends at the edge of the carriageway where users must give way. This route would be a great improvement on the current situation with no obvious disadvantages. However, regarding the egress point, if it were possible to direct the path along the grass verge parallel to the carriageway for a further 10 to 20m it would give cyclists the chance to 'merge' with Park Grange Rd traffic, making for a smoother transition.

### **Traffic Management Proposal Option 2**

A path that is both on and off road, starting at the junction of the Queen's Gardens access road, continuing off-road to the existing pedestrian crossing and turning to cross the tram tracks at 90° before re-joining the carriageway. Cyclists start by diverting left from the carriageway across the access road junction. There is limited visibility at this point and therefore little time to spot traffic joining Park Grange Rd from Queen's Gardens, although this is a very minor access road with no traffic usage at most times. New lining on the access road has been proposed to give priority to the cycle lane but caution is still advised, especially as cyclists may be travelling at high speed due to the downhill gradient. In any case, cyclists will need to be travelling at a sensible speed by the time they reach the off-road section, since this is only ~14 metres long with a 90° turn at the end, and may also be shared with pedestrians. As with any track crossing, good observation will be required here before crossing, and the same applies to re-joining the carriageway. A 'slip lane' here as per Option 1 would assist with this manoeuvre. This route would be an improvement on the existing situation, and requires less physical works. However it lacks the efficiency for cyclists of Option 1, largely due to the 90 degree turn across the tram tracks but also because of limited visibility crossing the junction.

### **Alternative Route Proposal Option 1**

Cyclists start at the junction of Park Spring Drive, continuing along Frank Wright Close and off-road past Queen's Gardens to the Queen's Gardens access road, then crossing the tram tracks and re-joining the carriageway as per Option 1. This is a good alternative route, getting the cyclist away from the tram tracks and actually providing a shorter route - 370m as compared to 450m along the tracks. The composition of the path is not known, so may be less suitable in wet weather unless it is proposed to upgrade it. Some users may also have personal safety concerns due to low usage. However the existing path appears to be illuminated. This seems to provide a good alternative route so long as it can be clearly signed for cyclists.

### **Road Safety comments**

Accsmap - Reported injury RTCs 1st November 2009 – 31st October 2014 (5 years)

No recorded injury collisions.

### **Traffic Management Proposal Option 1**

#### Problems

- Access point may need visual guidance to cyclists to avoid them taking a shallow angle across the rail, unless we assume they are riding on the existing red surfacing in the channel.
- The shared footway leading to the existing tram track crossing point should be 'squared up' so that cyclists have a better view of inbound trams.
- Downhill gradient on the cycleway to the Queens Garden access may be too steep. It may result in cyclists overshooting the footway onto the access road without giving way to pedestrians or vehicles.
- There is no indication to cyclists what stage the traffic signals are at and therefore there is a risk of vehicle / cycle conflicts (although it is accepted that there are only very light flows in and out of this access road).

#### Advantages

- Achieves the project objective.

### **Traffic Management Proposal Option 2**

#### Problems

- The cycle lane leading to the existing tram track crossing point should be 'squared up' so that cyclists have a better view of inbound trams. A cyclist may be unaware of an approaching tram and not carry out sufficiently thorough right shoulder checks to identify the danger.
- No indication is provided to cyclists to show what stage the traffic signals are running and therefore there is a risk of vehicle / cycle conflicts (although it is accepted that there are very light flows in and out of the access road).
- Extends exposure of cyclists to tram tracks when compared with option 1.

#### Advantages

- Cost effective solution with minimal installation work required.

## Alternative Route Proposal Option 1

### Problems

- May require maintenance at the concrete bus lay-by at the start of the route. This looks in poor condition at the joint and may create a problem for cyclists.
- The footpath width from Frank Wright Close to Queens Gardens may require increasing for shared use.
- The footpath is lit but might need upgrading
- Personal safety / street crime worries due to current low usage may deter use

### Advantages

- Bypasses the inbound Park Grange tram stop as well as the divergence at Queens Gardens.
- Re-joins private access road at the correct side of the signals so that cyclists can see what the signal aspect is.
- Bypasses a large section of the on-street running.

## Park Grange Croft - Budget Estimates

### Traffic Management Proposals

#### Option 1

	Estimate
Cycle Crossing off Park Grange Road	£ 1000
New Cycleway	£ 8000
Accommodation works for cycleway	£15000
Cycleway to tram crossing	£ 2500
Cycleway from tram crossing	£ 2500
Cycle Crossing on to Park Grange Road	£ 1000
Traffic Signs and Lines	£ 1900
<b>TOTAL:</b>	<b>£31,900</b>

#### Option 2

Cycle Crossing off Access Road	£1000
New Cycleway to tram crossing	£3800
Traffic Signs and Lines	£1000
<b>TOTAL:</b>	<b>£5800</b>

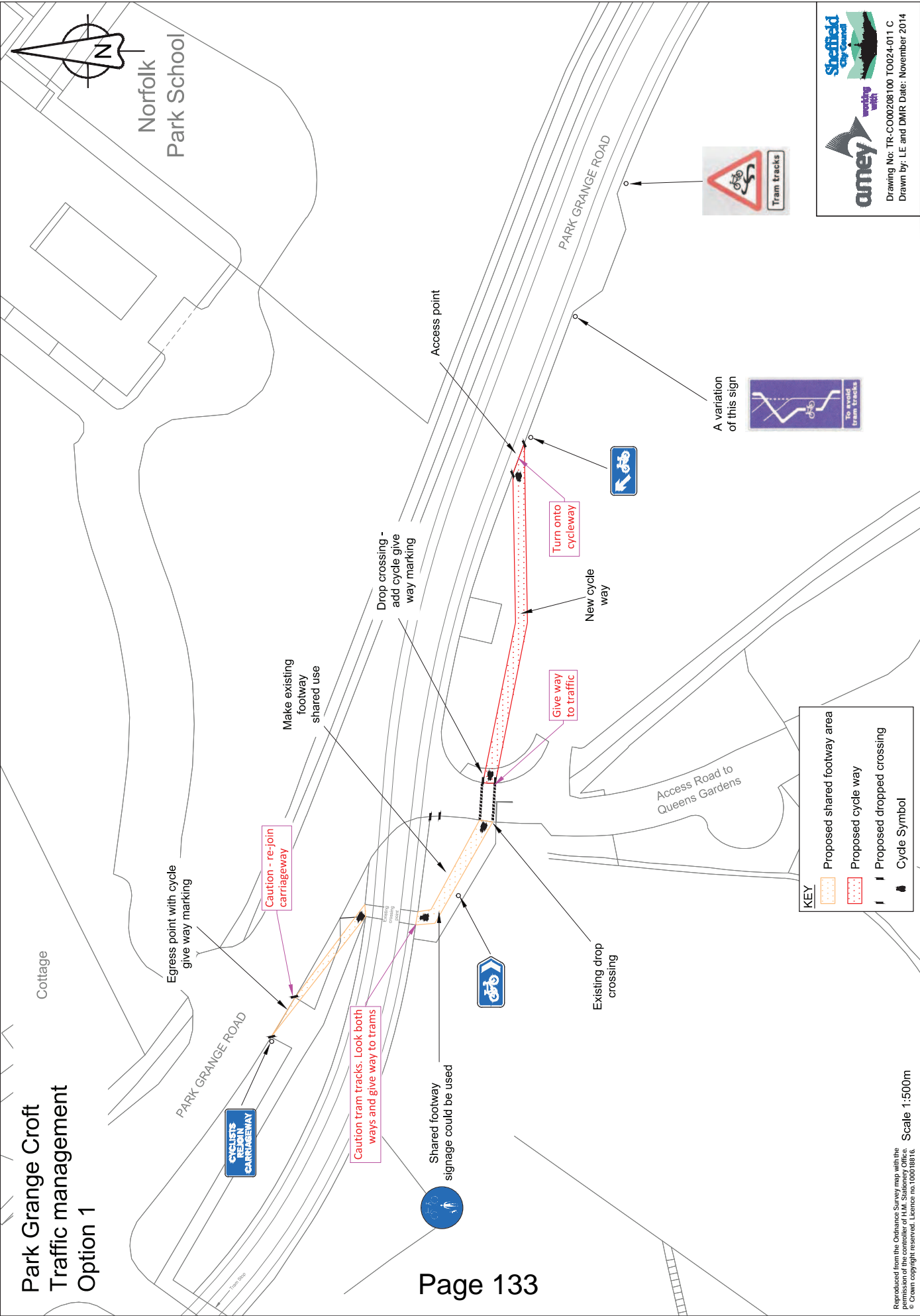
### Alternative Route Proposals

#### Option 1

	Estimate
Traffic Signs and Lines	<b>£1800</b>

*Construction costs estimate only – excludes cost of Electrical Servicing, Site Preliminaries, Traffic Management and Statutory Undertakers diversions, if required*





# Park Grange Croft Traffic management Option 1



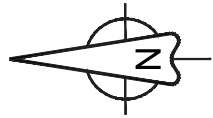


  
 Drawing No: TR-CO00208100 TO024-011 C  
 Drawn by: LE and DMR Date: November 2014

**KEY**

	Proposed shared footway area
	Proposed cycle way
	Proposed dropped crossing
	Cycle Symbol

**Park Grange Croft  
Traffic management  
Option 2**



PARK GRANGE ROAD

Egress point with cycle  
give way marking



Make existing  
footway  
shared use

Shared footway signage  
could be used



Caution  
re-join  
carriageway

Caution - tram tracks.  
Look both ways and  
give way to trams

Section of cycle  
way is off highway

Watch for traffic -  
reduced visibility

Access Road to  
Queens Gardens

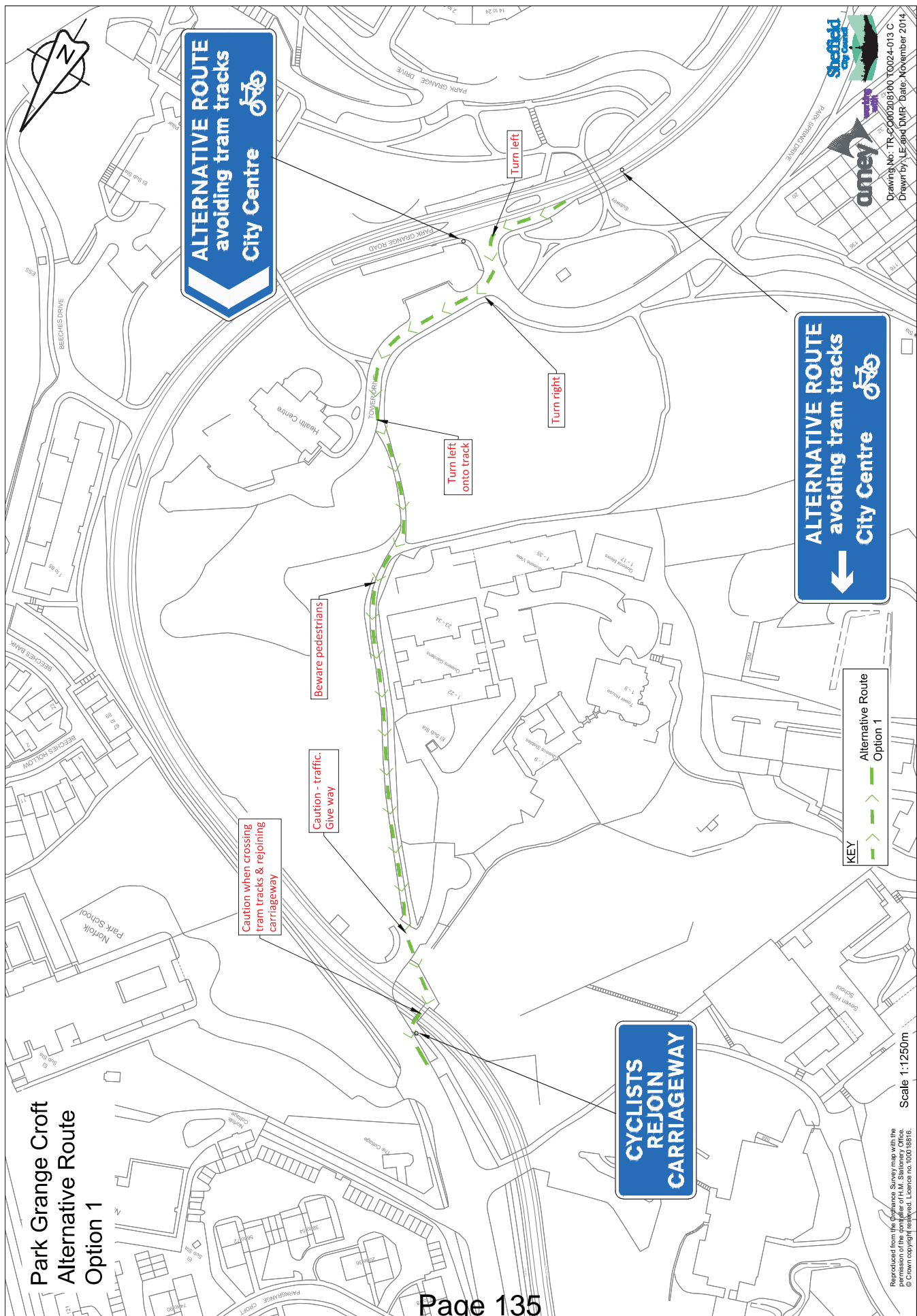
**KEY**

	Proposed cycle lane
	Cycle Symbol

amey  
Sheffield City Council

Drawing No: TR-CO00208100 TO024-012 C  
Drawn by: LE and DMR Date: November 2014

**Park Grange Croft  
Alternative Route  
Option 1**



**ALTERNATIVE ROUTE**  
avoiding tram tracks  
City Centre

**ALTERNATIVE ROUTE**  
avoiding tram tracks  
City Centre

**CYCLISTS  
REJOIN  
CARRIAGEWAY**

**KEY**  
Alternative Route  
Option 1

Sheffield City Council  
omey  
Drawing No: TR-C000209100 T0024-013 C  
Drawn by: LE and DMW Date: November 2014

Scale 1:1250m

Reproduced from the Ordnance Survey map with the permission of the controller of H.M. Stationery Office. © Crown copyright reserved. Licence no. 100016616.

## 6. OCCUPATION LANE/SHEFFIELD ROAD

The Occupation Lane, Sheffield Road junction is close to the Hackenthorpe tram stop and is part of the blue route which links the City Centre to the south east of Sheffield. The area of concern is the section of tram tracks which leaves the carriageway to go off road just after the junction of Occupation Lane. Reported accidents at this section include cyclists who have slipped on the rails and have had wheels caught in the rails. A range of weather conditions were reported at these accidents.



### **Traffic Management Proposal - for turning right into Occupation Lane from Sheffield Road Option 1**

This option includes a new right turn lane for cyclists on Sheffield Road ahead of the existing traffic signal junction with Occupation Lane. This allows those wanting to turn right onto Occupation Lane to carry out the manoeuvre away from the tram tracks. The route would then utilise an existing crossing point which goes over the tram tracks at close to 90 degrees. Further parts of the route would include a shared use footway with relevant shared use signage. Some physical works may need to take place here to widen the existing footway and there may also be the need to acquire some land in order to carry out this widening. Cyclists can then re-join the carriageway on Occupation Lane using the existing crossing (currently uncontrolled). Signage would include some advance direction signs, some hazard signs for cycles and route signage to show at what point to cross the tram tracks. Department for Transport (DfT) approval would be required for some of these signs (Drawing no. 014).

### **Traffic Management Proposal – for continuing on Sheffield Road Option 1**

Option includes an area of shared footway with relevant shared footway signage to create a facility for cyclists to leave the main carriageway to avoid the tram tracks. Cyclists can return to the main carriageway by first crossing Occupation Lane using the existing crossing (not currently controlled) and then re-joining Sheffield Road via the existing cycle crossing point. The shared footway could include some cycle symbols and red surfacing to enhance the area if necessary. Some physical work



might be required at the existing uncontrolled crossing. Also the crossing could be converted into a signal controlled crossing if necessary. Further signage would include some advance direction signs, some hazard signs for cyclists and route signage to show at what point to cross the tram tracks. DfT approval would be required for some of these signs (Dwg no. 015)

## **Alternative Route Proposals**

No alternative routes were identified for this site.

## **Cyclist Usability comments**

### **Traffic Management Proposal - for turning right into Occupation Lane from Sheffield Road**

#### **Option 1**

A right-turn lane is provided for cyclists to gain access to the cycle crossing over the tram tracks. Cyclists must first signal right and move out into the turning lane. Given the likelihood of oncoming traffic this will probably involve coming to a halt in the centre of the carriageway, so this will require a measure of control and confidence. Once the way is clear they will turn right and cross the tram tracks using the existing crossing, giving way to trams where necessary. They will then turn sharp left onto the shared use footway, continuing to the junction with Occupation Lane. The crossing at this point is uncontrolled, meaning that cyclists will have to observe and give way to traffic from 3 directions before continuing NW along Occupation Lane. Both this last turn and the initial right turn are fairly hazardous for the reasons already given, and could also involve some delays. Delays and minor hazards could also be encountered on the shared use path. However, in practice, some cyclists might choose instead to stop adjacent to the junction, cross as a pedestrian and continue on their way, as this might incur less delay and no greater risk.

### **Traffic Management Proposal – For continuing on Sheffield Road**

#### **Option 1**

An off-road, shared-use path is provided on the left-hand (north) side of Sheffield Rd. Cyclists must cross Occupation Lane (this is uncontrolled so the usual precautions apply) and continue along the shared-use path adjacent to the tram tracks. After approx. 120m cyclists must turn sharp right across the tramway crossing, giving way to trams where necessary, and finally check for eastbound traffic before re-joining the carriageway. Aside from the crossing of Occupation Lane, there are minor hazards and delays inherent in the use of the off-road path, the tram crossing and the re-joining of Sheffield Rd. It is possible that some cyclists might bypass some of these by staying on Sheffield Road, using their right of way to cross Occupation Lane, and then finding their own way onto the off-road path before re-joining Sheffield road at the earliest opportunity at the pedestrian crossing.

## **Road Safety comments**

Accsmap - Reported injury RTCs 1st October 2009 – 30th September 2014 (5 years)

1 x slight injury crash: Shunt Car v Car Westbound approaching traffic signals no pedal cycle involvement.

**Traffic Management Proposal - For turning right into Occupation Lane from Sheffield Road - Option 1**

Problems

- The footway width appears insufficient for shared use (the comment re widening is noted)
- Conflict at Occupation Lane, although the signal head opposite is visible and gives a cyclist some indication of what opposing traffic to expect.
- There appears to be insufficient carriageway width to support the right turn cycle lane, for both through traffic and cyclists utilising the facility. This is likely to be a major conflict point.
- Conflict at the cycle crossing which bisects the footway. This problem currently exists; suitable markings and/or the use of corduroy paving would address the problem.

Advantages

- Provides a parallel route, avoiding the problem section of track.

**Traffic Management Proposal – For continuing on Sheffield Road - Option 1**

Problems

- The footway width appears insufficient for shared use (the comment re widening is noted)
- Conflict at Occupation Lane, although the signal head opposite is visible and gives the cyclist some indication of what opposing traffic to expect.
- Conflict at the cycle crossing which bisects the footway. This problem currently exists; suitable markings and/or the use of corduroy paving would address the problem.

Advantages

- Provides a parallel route, avoiding the problem section of track.

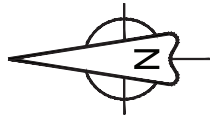
**OCCUPATION LANE/SHEFFIELD ROAD - Budget Estimate**

<b>Traffic Management Proposals</b>	Estimate
<b>Option 1 – for Occupation Lane</b>	
Footway widening to 3m	£8800
Hazard Warning Paving (2.4 x 3.0m)	£1800
Traffic Signs and Lines	£2200
<b>TOTAL:</b>	<b>£12800</b>
<b>Option 1 - for Sheffield Road</b>	
Footway widening to 3m	£5100
Traffic Signs and Lines	£2400
<b>TOTAL:</b>	<b>£7500</b>

*Construction costs estimate only – excludes cost of Electrical Servicing, Site Preliminaries, Traffic Management and Statutory Undertakers diversions, if required*

# Occupation Lane/Sheffield Road Traffic management

## Option 1 for turning right into Occupation Lane from Sheffield Road



Caution - give way to trams

Existing cycle crossing with cycle give way markings

Turn right when clear

Introduce some 'look both way' signs

Introduce new cycle right turn lane

Shared use footway - some footway widening may be required

Shared footway signage could be used

Give way to traffic

Use existing crossing points (not currently controlled) to rejoin carriageway



KEY	
	Proposed shared footway area
	Proposed cycle area
	Cycle Symbol
	Route across existing crossings

Throstle Nest Farm

SHEFFIELD ROAD

OCCUPATION LANE

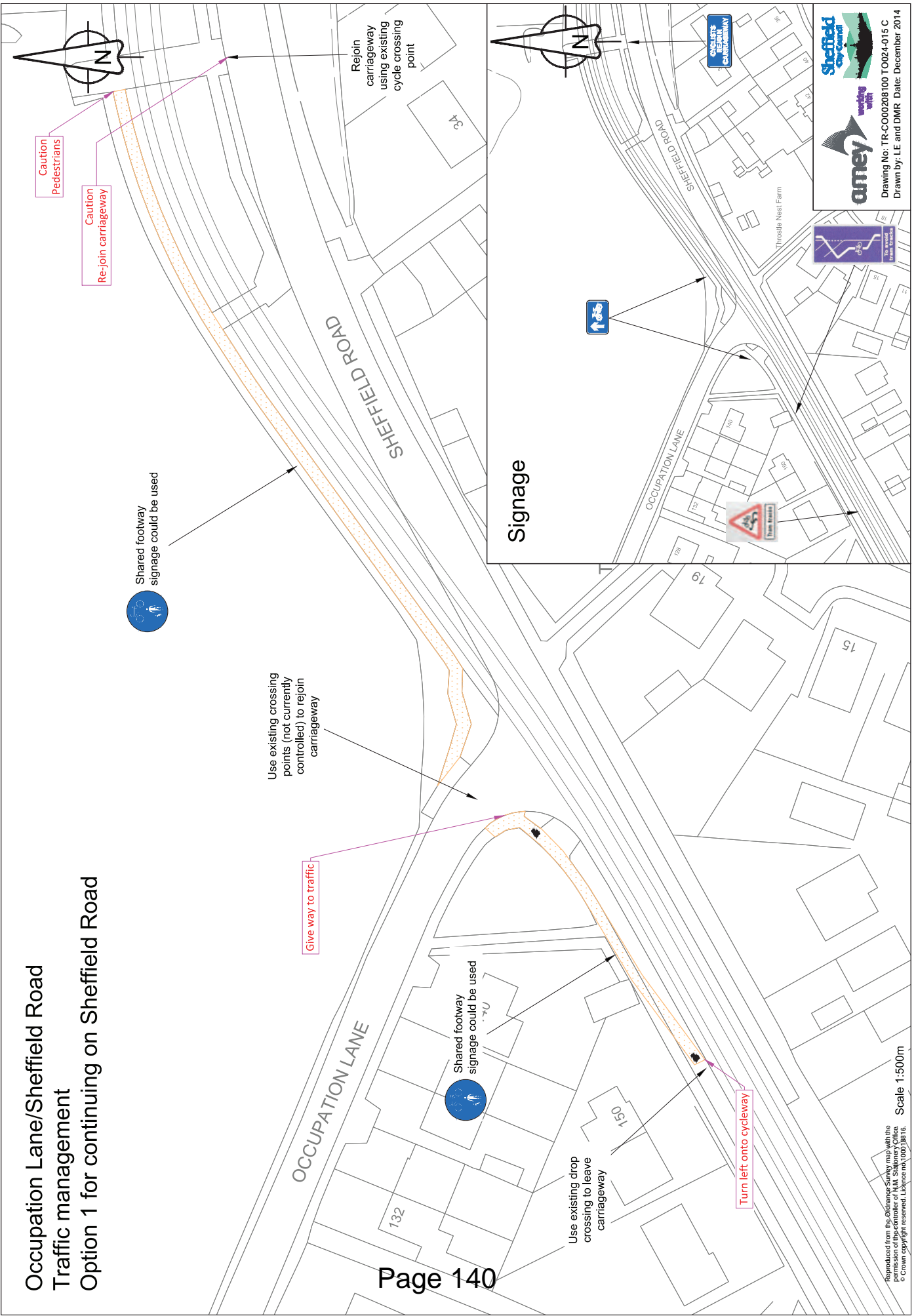
28  
26  
24  
30  
34  
36  
40

Drawing No: TR-CO00208100 TO024-014 C  
Drawn by: LE and DMR Date: December 2014

Scale 1:500m

Reproduced from the Ordnance Survey map with the permission of the Controller of Her Majesty's Stationery Office. © Crown copyright reserved. Licence no. 1000188316.

# Occupation Lane/Sheffield Road Traffic management Option 1 for continuing on Sheffield Road



Drawing No: TR-CO00208100 T0024-01 15 C  
 Drawn by: LE and DMR Date: December 2014

## 7. HILLSBOROUGH CORNER

Hillsborough Corner is a complex junction. It is part of the Malin Bridge route and the Hillsborough (Middlewood Road) route. It sees trams travelling in both directions. There are multiple approaches to the junction and many ways in which a cyclist could cross the tram tracks. The major area of concern is travelling out of the city on Langsett Road where multiple tracks cross the carriageway at various angles. There are no reported accidents at this particular junction but there have been some reported incidents in advance of the junction which involved cyclists being caught in the tracks. The weather conditions reported for these incidents were varied.



### Traffic Management Proposal for all approaches

#### Option 1

It is proposed that advance stop lines are introduced on signal approaches where there are no tram rails. This will give cyclists the chance to better position themselves to cross the tracks. It is also proposed that hazard signage is erected on each approach to the junction (Drawing no. 016).

### Traffic Management Proposals for left turn into Holme Lane from Langsett Road or to continue on Langsett Road

#### Option 1

Option includes an area of shared footway with relevant shared footway signage to create a facility for cyclists to leave the main carriageway to avoid the tram tracks. Cyclists would re-join the carriageway after the junction Langsett Road/Holme Lane if travelling towards Malin Bridge or by using the existing crossing point if travelling towards Middlewood. Some street furniture would need to be moved to implement the shared footway. The shared footway area could contain some cycle symbols and some red surfacing to enhance the area if necessary. In addition to this, some physical works including dropped crossings would be required to provide access and egress points. Signage would include hazard warning signs and route signage. Department for Transport (DfT) approval would be required for some of these signs (Dwg no. 017).

## **Option 2**

Option includes an area which could be defined by a new cycle road markings to guide cyclists across the tram tracks. Some coloured surfacing could also be used to enhance the area if necessary (Dwg no. 018).

## **Alternative Route Proposal - For left turn into Holme Lane from Langsett Road or to continue on Langsett Road**

### **Option 1**

Option includes an alternative route for cyclists avoiding the tram tracks at the junction of Langsett Road/Holme Lane (approx. 300m). The route would use the carriageway rather than footways. Signage would direct cyclists away from Langsett Road onto a contra flow cycle lane on Forbes Road. Some physical and signalling works would need to take place here to re-align the junction in order to introduce this short contra-flow lane. The route would continue using Walkley Lane and cyclists would reach the end of the route at Holme Lane. Currently the junction of Walkley Lane/Holme Lane is left turn only. Thought would need to be given to making this a right hand turn junction for cyclists only if cyclists needed to travel towards Middlewood rather than just Malin Bridge. Alternatively for those travelling towards Malin Bridge, the alternative route proposed for the Malin Bridge site as part of this study (Dwg no. 005) could also be used. Signage would include advance direction signs, repeat signage along the route. DfT approval would be required for some of these signs (Dwg No. 019).

## **Cyclist Usability comments**

### **Traffic Management Proposal for all approaches**

#### **Option 1**

ASLs are to be provided at the above junctions. The purpose of these facilities is to allow cyclists to adopt a suitable position in the lane while traffic is stopped (e.g. to move to the right before a right turn). Theoretically this should be done on the approach to the junction but dense traffic can sometimes make this risky and difficult. The proposed Bradfield Rd ASL will span both lanes and be useful in allowing cyclists to adopt a commanding position in the RH lane in order to proceed safely across the junction onto Holme Lane. The proposed Langsett Rd ASL will make it easier for cyclists to plan and signal their next move, as well as providing a 'head start' for manoeuvres which might otherwise bring them into conflict with faster traffic. These manoeuvres are detailed further in Traffic Management – Option 2. The Holme Lane ASL seems to have a fairly limited purpose in the proposed form, since right turns are prohibited from this lane. The left turn poses no particular hazard, but going straight ahead there is admittedly a slight risk of 'crowding' by impatient motorists trying and failing to get past before the Bradfield Rd traffic island, which would be alleviated by the ASL. An ASL on the right-hand turning 'tram/bus lane' would arguably have greater benefits, as it would allow cyclists to pick their course through the tangle of tram tracks between the stop line and the opposite kerb with minimal risk of intimidation by faster traffic. However there are difficulties with providing ASLs over tram tracks, and cyclists may have problems finding a suitable stopping position around the rails.

### **Traffic Management Proposals for left turn into Holme Lane from Langsett Road or to continue on Langsett Road**

#### **Option 1**

Set off from the left of the lane and cross the tram tracks almost immediately, then stays in the LH zone between kerb and rail and turn left onto Holme Lane.

This seems a fairly straightforward manoeuvre, requiring only a LH shoulder check for trams (and errant cars!) exiting the tram stop.

Turn part-way into Holme Lane; signal right (or dismount) and cross the carriageway and Malin Bridge-bound tracks onto the pedestrian crossing. Cross the Halfway-bound tracks and remount at the RH (NE) end of the pedestrian refuge to avoid conflict with pedestrians. Cross the NE-bound lane of Holme Lane when clear, and re-join Middlewood Rd exercising appropriate caution.

This potentially requires giving way to 3 (possibly 4) streams of traffic depending on the speed of the cyclist (variable) and the length of the various traffic light phases (unknown). At any rate it causes an unreasonable delay to all but the most unhurried of cyclists, while merely swapping one type of hazard for another.

Cyclists might also opt to turn part-way into Holme Lane, signal right and cross the Malin Bridge-bound tracks at a suitable angle, and then stay in the left hand zone continuing towards Middlewood. This runs the risk of misinterpretation by motorists but has the advantage of staying with the main flow of traffic, thereby keeping delays to a minimum.

## **Option 2**

Set off from the right of the lane (outside the RH rail), maintaining a brisk pace, then turn left across the Middlewood-bound tracks immediately after passing the Malin Bridge tracks, either continuing along Middlewood Rd or making a late turn onto Holme Lane. Caution:

When continuing to Middlewood there is a risk of faster traffic failing to understand the cyclist's intentions and attempting to 'undertake' in frustration at the cyclist's unconventional road positioning, so a left-hand shoulder check is essential, combined with eye contact and a clear signal if necessary.

When making the late turn onto Holme Lane, there is a danger of being 'undertaken' by left-turning traffic - drivers might reasonably think the cyclist is continuing straight ahead, and/or misinterpret any signals as relating to a change of position within the Middlewood-bound lane.

Alternatively, maintain position in the extreme right of the lane, crossing the Halfway-bound tracks at a suitable angle, continuing until clear of the junction, and then moving back to the left when clear. Caution: risk of undertaking/ driver frustration as above. This manoeuvre requires a good turn of speed to minimise this possibility. Shoulder check + eye contact/ signal as necessary.

When looking at these options and the problems inherent in each, it should be emphasised that there probably is no 'ideal' solution. The complexity of this junction, the levels of traffic using it and the inability to change the tram rail alignment all combine to make this a difficult environment for cyclists to ride through. However these options suggest that it ought to be possible to provide for cyclists without subjecting them to unreasonable delays and/or detours.

## **Alternative Route Proposal - For left turn into Holme Lane from Langsett Road or to continue on Langsett Road**

### **Option 1**

Cyclists turn left from Langsett Rd onto Forbes Rd, using the proposed contraflow cycle lane. This road is currently one-way only and is mainly used by buses, which make a sharp right-hand turn at the bottom to enter the bus station opposite. It seems likely that such manoeuvres would tend to encroach on the proposed cycle lane in practice, regardless of the presence of a white line on the road! There is also a short but steep gradient, the road rising at approx. 10% for 60m or so. The junction with Walkley Lane is less than ideal, since visibility is reduced by parked cars at almost all times and, additionally, the frequent buses turning into Forbes Road will tend to occupy more than their fair share of the road in doing so. This might cause difficulties for cyclists moving into the right-turn position when a bus is arriving. Having reached this junction they then turn right onto Walkley Lane, descending again to the junction with Holme Lane, where they may turn left for Malin Bridge. The right-hand turn shown is currently prohibited, so that this would need to be opened up for use by cyclists if this were to become a viable route back to Holme Lane and Middlewood Rd.

In practice, some cyclists with good local knowledge might choose to use the narrow footpath leading round the back of the Rawson Spring pub to Walkley Lane as an alternative route. However this is far too narrow, and is constrained between tall walls on both sides, to allow its designation for general use as a shared cycle/footway facility.

### **Road Safety comments**

Accsmap - Reported injury RTCs 1st October 2009 – 30th September 2014 (5 years)

30 collisions (10 x Serious, 20 x Slight) one involved a pedal cyclist who caught front wheel in tram tracks - see RTC Plot / Interpreted Data.

### **Traffic Management Proposal for all approaches**

#### **Option 1**

##### Problems

- Access to the lead in taper of the Advanced Stop Line (ASL), because of limited carriageway width at Holme Lane and Bradfield Road, may be problematical. It could encourage cyclists to be caught on the nearside of left turning vehicles in a driver blind spot and in danger of collision.
- Obstructive parking takes place regularly at the Holme Lane site (by delivery vehicles for the fast food outlets). This would create an additional hazard including the danger of the negligent opening of car doors.

##### Advantages

- At the ASL cyclists would be able to position themselves advantageously to deal with the road layout ahead.

### **Traffic Management Proposals for left turn into Holme Lane from Langsett Road or to continue on Langsett Road**

#### **Option 1**

##### Problems

- The footways, regardless of width, are extremely busy and should not be converted to shared use.
- There are multiple conflicts with other traffic for a cyclist traversing this route. This may conflict with the traffic signal phasing of other traffic streams and lead to a more dangerous situation than currently exists.
- The Langsett Road and Holme Lane routes emerge onto carriageway adjacent to the tram rails which may create an additional conflict.
- The proposal to route cyclists through the tram stop at Langsett Road could be hazardous as many pedestrians cross heedless of traffic at the Forbes Road and Rudyard Road crossing points. These pedestrians would not be expecting a pedal cyclist to use the tram stop area.

##### Advantages

- None apparent.



## **Option 2**

### Problems

- The use of further markings on the carriageway can create particular problems for powered two wheelers, pedal cyclists and pedestrian traffic because it may create a slip hazard.
- The route of the cyclist immediately prior to commencing a left turn to Holme Lane is likely to result in collisions with other traffic when the cyclist veers unexpectedly to the left.
- The left turn at the Middlewood Road side of the junction, from between opposing rails to the nearside kerb line, is likely to result in collisions with vehicles that have undertaken the cyclists.

### Advantages

- Notwithstanding the above, it defines a cyclist's route which may raise the awareness of other road users.

## **Alternative Route Proposal - For left turn into Holme Lane from Langsett Road or to continue on Langsett Road**

### **Option 1**

#### Problems

- Uphill gradient at Forbes Road may discourage use especially by the less able cyclist.
- Conflict turning left from Langsett Road to Forbes Road with opposing right turning traffic from Forbes Road.
- Contraflow cycling on Forbes Road, conflict with manoeuvring buses.
- Conflict because of parked vehicles restricting inter-visibility at Forbes Road into Walkley Lane.
- Right turn from Walkley Lane to Holme Lane is currently a prohibited turn.

#### Advantages

- Fulfils the design brief in providing a cycle route avoiding the interlaced track at Hillsborough Corner.

## Hillsborough Corner - Budget Estimates

### Traffic Management Proposals Estimate

#### Option 1 – Various Approaches

Traffic Signs and Lines	<b>£1000</b>
-------------------------	--------------

#### Option 1

Cycle Crossing off Langsett Road	£3700
----------------------------------	-------

Cycle Crossing on to Holme Lane	£4200
---------------------------------	-------

Traffic Signs and Lines	£1800
-------------------------	-------

<b>TOTAL:</b>	<b>£9700</b>
---------------	--------------

#### Option 2

Traffic Signs and Lines	<b>£1000</b>
-------------------------	--------------

### Alternative Route Proposals Estimate

#### Option 1

Realign Junction - Forbes Road	£4200
--------------------------------	-------

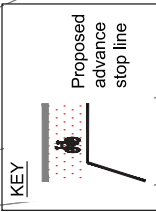
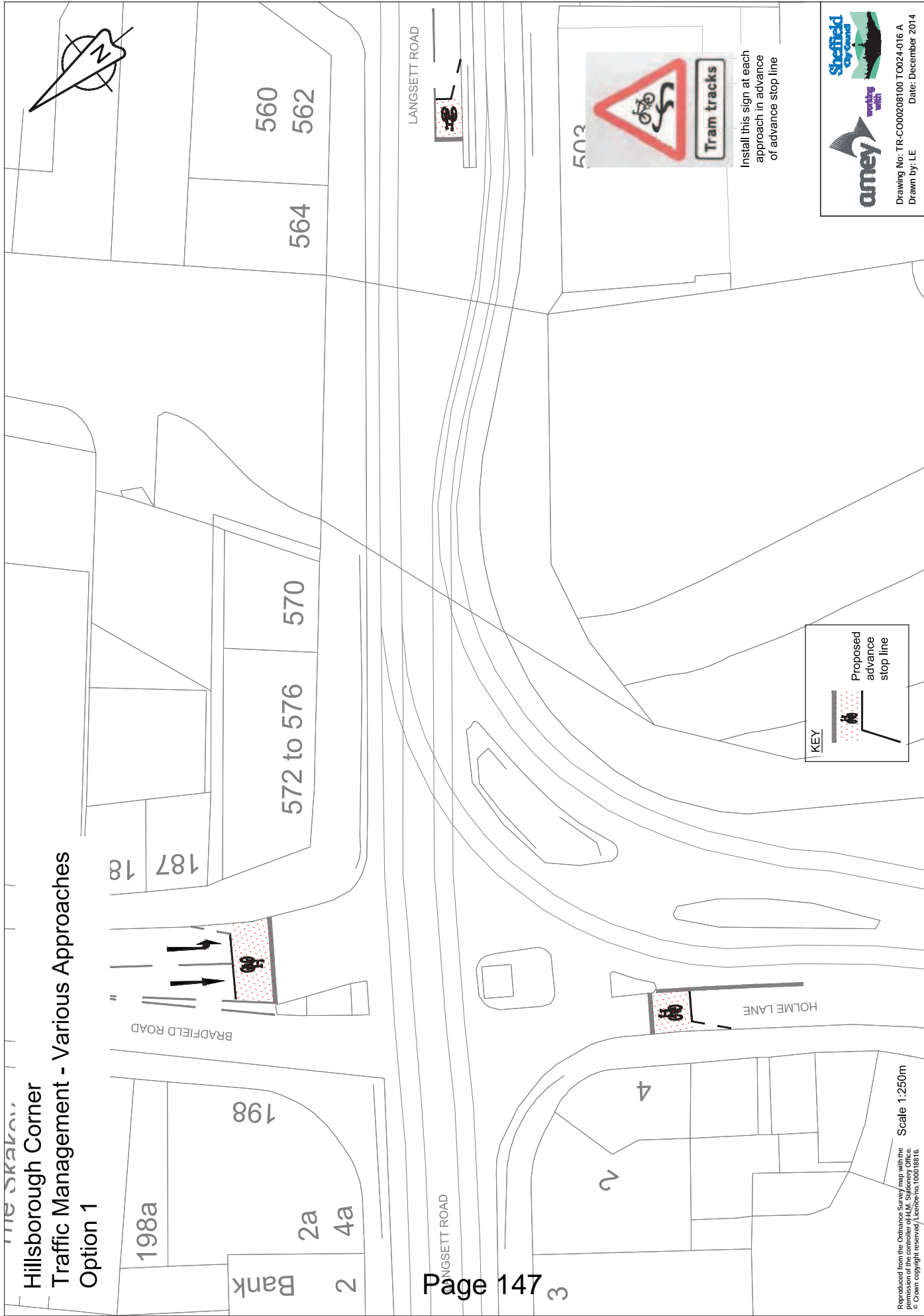
Traffic Signs and Lines	£1000
-------------------------	-------

Traffic Signal alterations	£8500
----------------------------	-------

<b>TOTAL:</b>	<b>£13700</b>
---------------	---------------

*Construction costs estimate only – excludes cost of Electrical Servicing, Site Preliminaries, Traffic Management and Statutory Undertakers diversions, if required*

Hillsborough Corner  
 Traffic Management - Various Approaches  
 Option 1

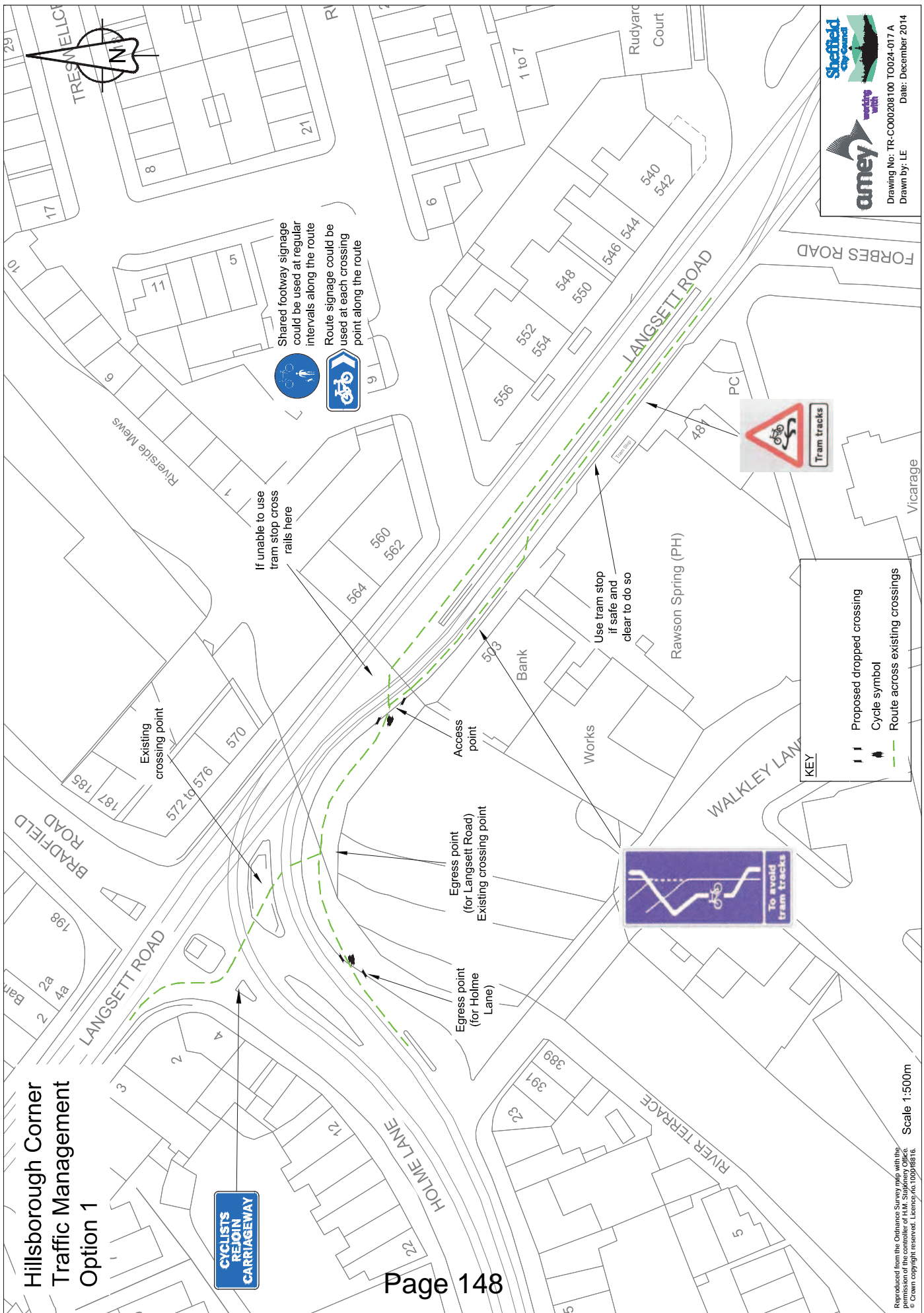


Install this sign at each approach in advance of advance stop line

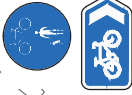
amey  
 Sheffield City Council  
 working with

# Hillsborough Corner Traffic Management Option 1

**CYCLISTS  
REJOIN  
CARRIAGEWAY**



Shared footway signage could be used at regular intervals along the route



If unable to use tram stop cross rails here

Use tram stop if safe and clear to do so

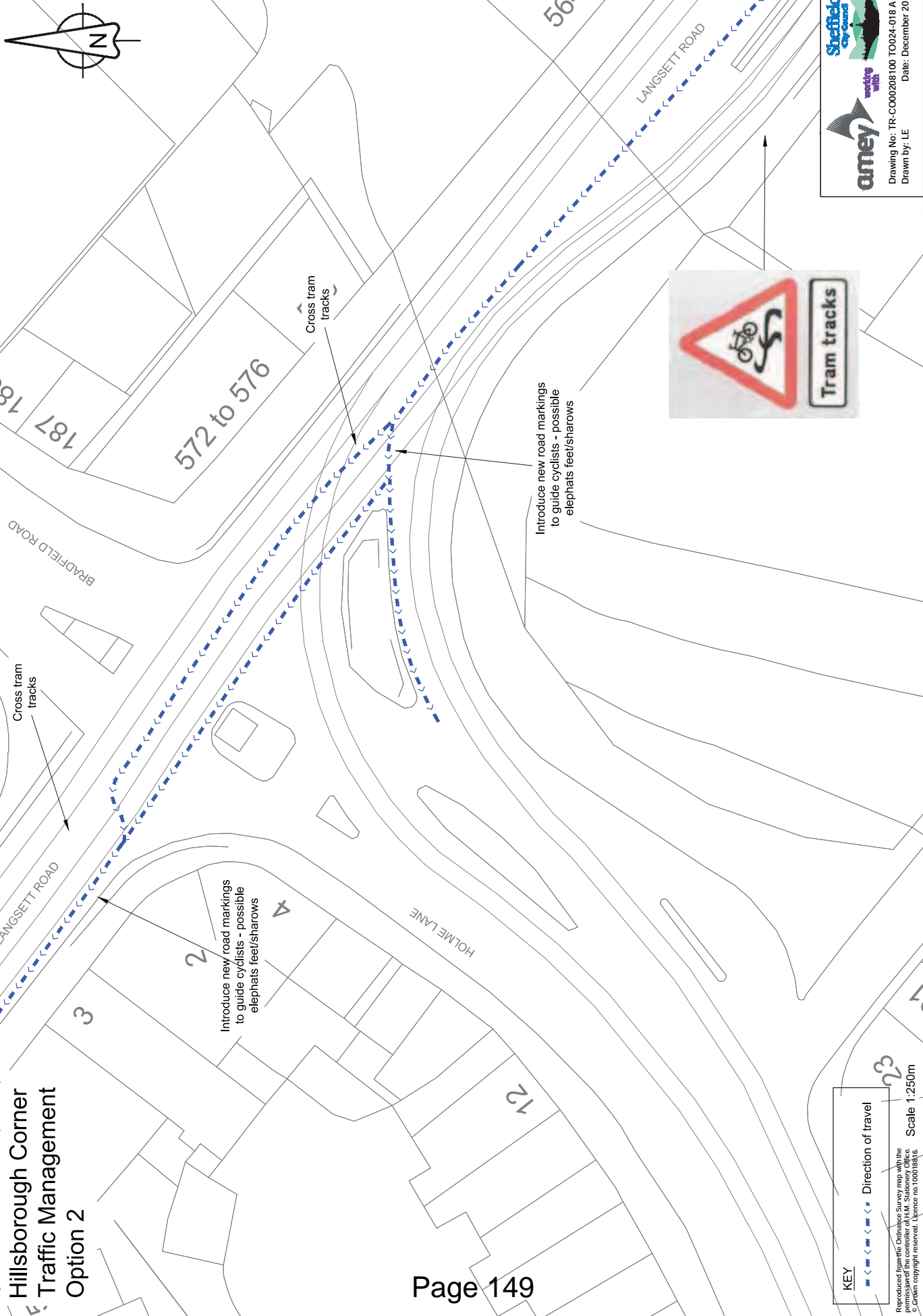
**KEY**

- Proposed dropped crossing
- 🚲 Cycle symbol
- - - Route across existing crossings



Drawing No: TR-CO00208100 TO024-017 A  
 Date: December 2014  
 Drawn by: LE

**Hillsborough Corner  
Traffic Management  
Option 2**



187 185  
572 to 576

564

LANGSETT ROAD

BRADFELD ROAD

Cross tram tracks

Cross tram tracks

Introduce new road markings to guide cyclists - possible elephants feet/sharrows

Introduce new road markings to guide cyclists - possible elephants feet/sharrows

HOLME LANE

3

2

12



KEY  
 - - - - - Direction of travel  
 - - - - - Tram tracks

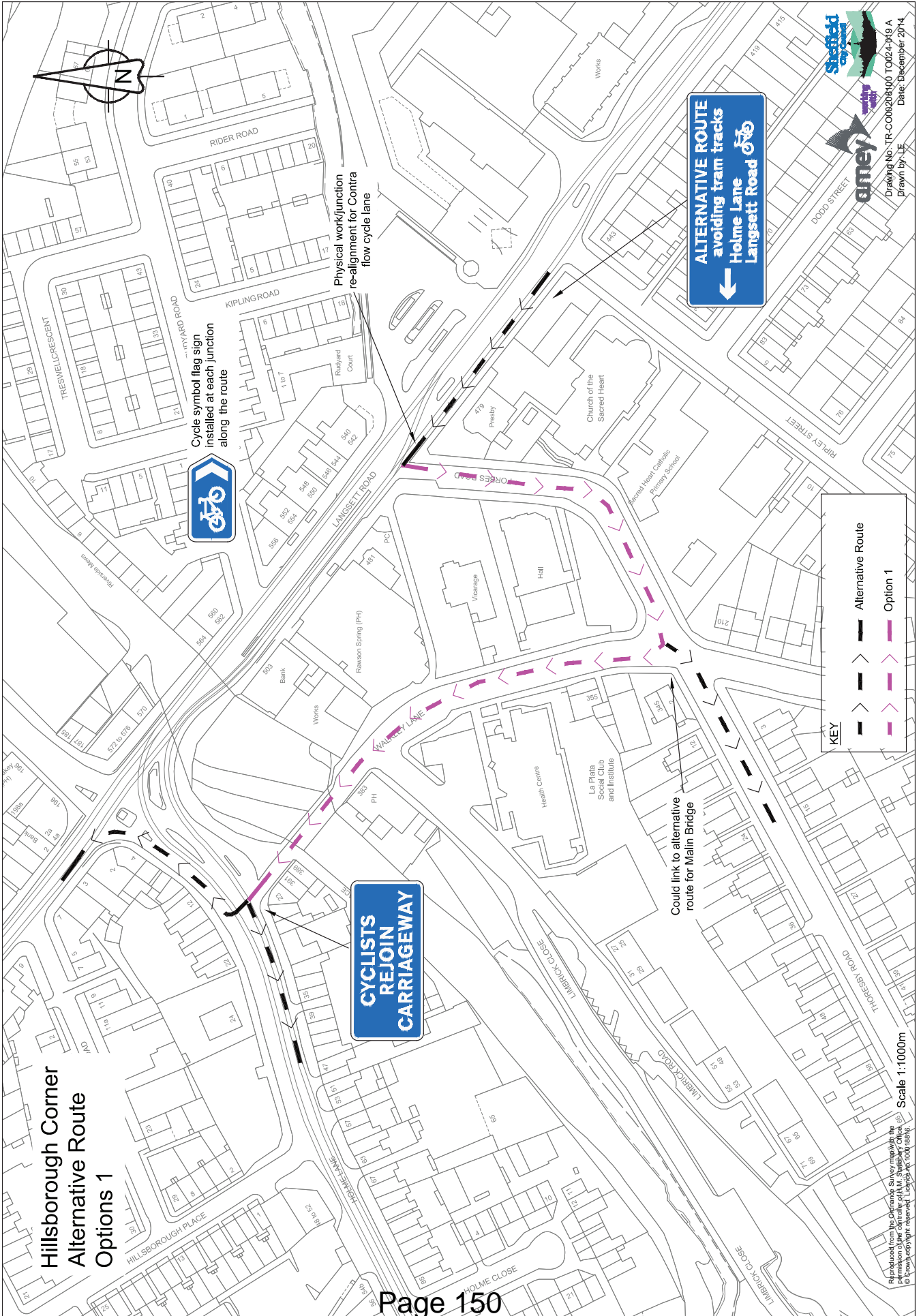
Reproduced from the Ordnance Survey map with the permission of the Ordnance Survey. © Crown copyright reserved. Licence no. 1000188316.

Scale 1:250m

amey  
 Sheffield City Council  
 warrington council

Drawing No: TR-CO00208100 TO024-018 A  
 Date: December 2014  
 Drawn by: LE

**Hillsborough Corner  
Alternative Route  
Options 1**



KEY	
--->	Alternative Route
->	Option 1

## 8. GLOSSOP ROAD / UPPER HANOVER ST

Glossop Road/Upper Hanover Street junction connects West Street tram stop and University tram stop. It is part of the yellow and blue routes which link the north of Sheffield as far as Middlewood to the City Centre. The area of concern is the direction where cyclists are travelling from Glossop Road towards West Street and the tram tracks cross the carriageway at a 35 degree angle. Reported accidents at this section include cyclists who have slipped on the rails and been caught in the rails. The conditions at these accidents were reported as wet.



### Traffic Management Proposals

It is considered that there aren't any viable localised traffic management options at this location. With heavy pedestrian activity around the junction (particularly for the University tram stop) and limited physical space, it hasn't been possible to find a satisfactory option to improve the track crossing arrangements in the immediate vicinity of the junction.

### Alternative Route Proposals

This option includes an alternative route for cyclists avoiding the tram tracks at the junction of Glossop Road/Hanover Street. The route would make use of current cycle facilities on and off carriageway. Signage would direct cyclists away from Glossop Road onto Brunswick Street. There are already some cycle direction signs along the route. Further signage would be included to highlight the 'alternative route avoiding tram tracks'. Repeat signage could also be erected at each junction along the route. DfT approval would be required for some of these signs (Dwg No. 020).

### **Option 1**

Route: Glossop Road to West Street via Brunswick Street, Broomspring Lane and Gell Street (approx. 700m). This route takes advantage of some existing signed and advisory cycle routes on the Sheffield Cycle Network using an already established cycle right turn filter lane and contra flow cycle way

### **Option 2**

Route: Glossop Road to City Centre via Brunswick Street, Broomspring Lane and a traffic free cycle path (approx. 700m). This route uses some of the above and extends as a route towards the City Centre rather than West Street. This route takes advantage of some existing signed and advisory cycle routes on the Sheffield Cycle Network using an already established cycle right turn filter lane, contra flow cycle lane and off carriageway/traffic free cycle ways.

### **Option 3**

Route: Upper Hanover Street to Upper Hanover Street via Leavygreave Road, Gell Street and Broomspring Lane (approx. 600m). This route takes advantage of some existing signed and advisory cycle routes on the Sheffield Cycle Network.

## **Cyclist Usability comments**

None provided. The proposed alternative routes are all existing cycle routes.

## **Road Safety comments**

Accsmap - Reported injury RTCs 1st January 2010 – 31st December 2014 (5 years)

13 collisions (1 x Fatal; 3 x Serious; 9 x Slight). One involved a pedal cyclist who fell from his cycle into the path of a van & trailer at the Brunswick Street/Broomspring Lane junction sustaining slight injuries. See RTC Interpreted Data.

## **Alternative Route Proposal 1, 2 and 3**

### **Problems**

- Right turn filter lane at Glossop Road/Brunswick Street is very narrow and unmarked (on the carriageway) for cycle use. The width is such that there is a risk of cyclists getting side swiped by the traffic passing either side.
- The footway widths are not wide enough to support shared use at Gell Street; this is particularly bad in the vicinity of the University health centre premises where pedestrian volumes are high.
- The northbound route at Gell Street/Glossop Road ends at a point where there is a high risk of conflict and interface with tram tracks.
- The footway at Upper Hanover Street is extremely busy this would be unsuitable to support shared use.
- There are potential conflicts at the Upper Hanover Street / Leavygreave Road junction with pedestrians at the corner and larger vehicles making the left turn from the ring road (e.g. buses take a wide line and often encroach into the offside cycle lane on Leavygreave, whilst almost overrunning the footway with their rear nearside wheels).



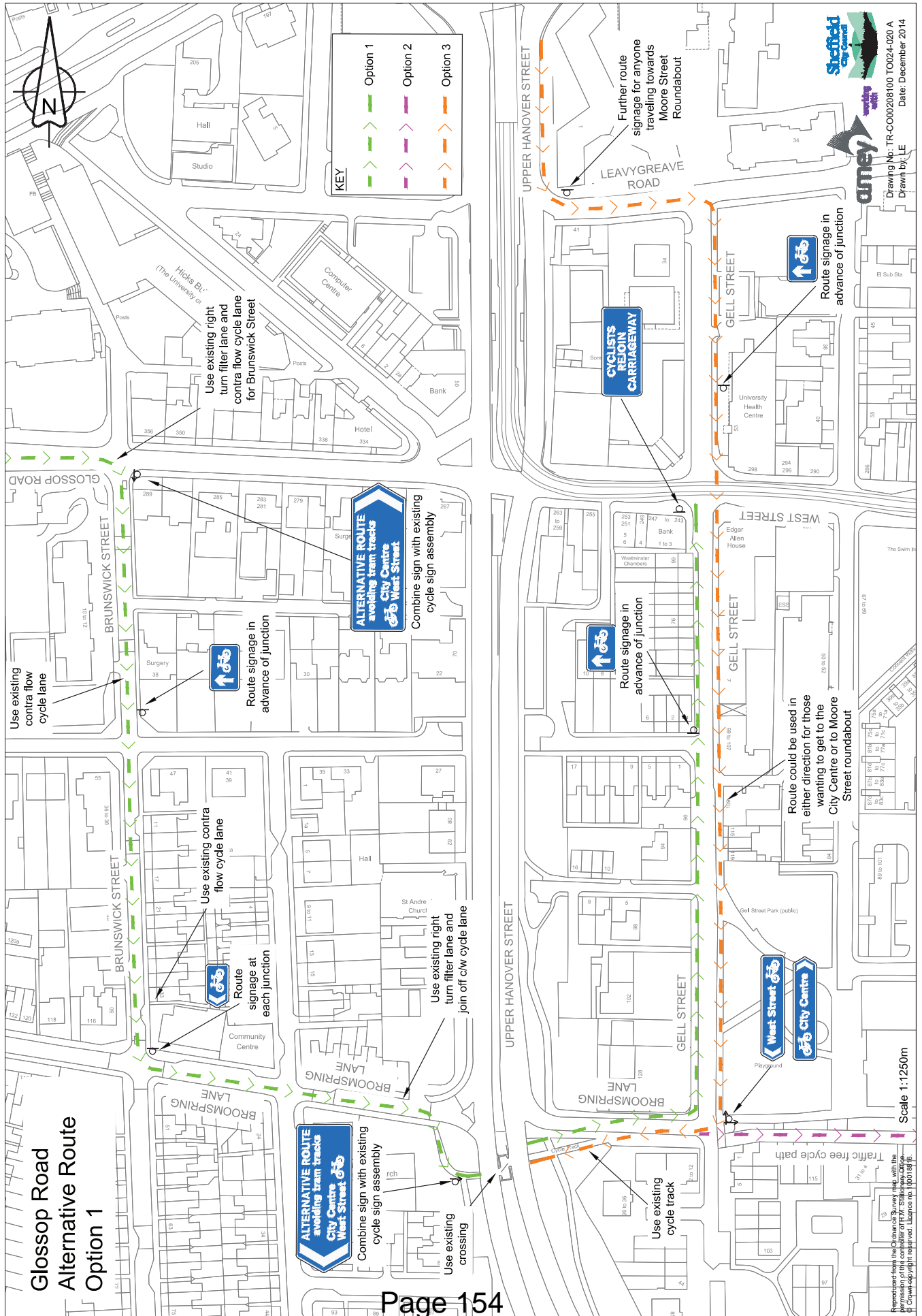
Advantages

- Fulfils the design brief in providing a cycle route avoiding the track at Glossop Road/Upper Hanover Street. (Except at the northbound leg of Gell Street as mentioned above).

**Glossop Rd / Upper Hanover St - Budget Estimate**

<b>Alternative Route Proposals</b>	Estimate
<b>Option 1</b>	
Traffic Signs and Lines	<b>£1800</b>
<b>Option 2</b>	
Traffic Signs and Lines	<b>£1800</b>
<b>Option 3</b>	
Traffic Signs and Lines	<b>£1400</b>

*Construction costs estimate only – excludes cost of Electrical Servicing, Site Preliminaries, Traffic Management and Statutory Undertakers diversions, if required*



**Glossop Road  
Alternative Route  
Option 1**

**KEY**

	Option 1
	Option 2
	Option 3

Sheffield City Council  
 amey  
 Drawing No: TR-CO0208100 T0024-020 A  
 Date: December 2014  
 Drawn by: LE

Remodified from the Ordnance Survey map, with the permission of the controller of H.M. Stationery Office. © Crown copyright reserved. Licence no. 10010816.

Scale 1:1250m

## Appendix 5

# Desktop Assessment of other Problems Sites

These problem sites on the list were considered primarily through a desktop exercise, using plans, Internet viewing facilities and the expertise and experience of other Amey staff who have previously been involved in design issues at these sites. The development of the options indicated below is an extension of the work carried out on the more detailed investigations on the other problem sites in Sheffield which are described in Appendix 4.

Some of the signs and lines required for these options would require Department for Transport authorisation.

Brief notes, images and sketch concept layouts are provided below:

## Birley Lane



### **Option 1 - using new track crossing**

This arrangement would allow cyclists to leave the carriageway travelling westbound on the left hand side at the junction with the golf course and join the existing footway heading towards Birley tram stop. This would require the footpath to be converted to a formal shared cycle/footway with signs and road markings. It is noted that the unusual switchback levels of the first part of the footpath are not ideal for cycle usage. It would then cross the tram tracks using a new track crossing located shortly after the tram tracks leave Birley Lane. It would re-join the carriageway at the end of the crossing point with a give-way point to any oncoming traffic. This option might require: a new track crossing facility, possible widening of footway to a cycle/footway and signing and lining.

### **Option 2 - using existing track crossing**

This option is similar to Option 1 above, except that cyclists would ride further along the shared cycle/footway before using the existing pedestrian crossing over the tracks located further along the tram stop. Cyclists would re-join the carriageway at the end of the existing track crossing point via a new dropped crossing onto Birley lane. This option might require: possible widening of footway to cycle/footway, a new dropped crossing for cyclists only and signing and lining.



Option 1 - Using new track crossing  
 Option 2 - Using existing track crossing



BIRLEY LANE



New drop crossing

Reproduced from the Ordnance Survey map with the permission of the Ordnance Survey. © Crown copyright reserved. Licence no. 100018816.

## Birley Moor Road



### **Option 1 – Using existing crossings**

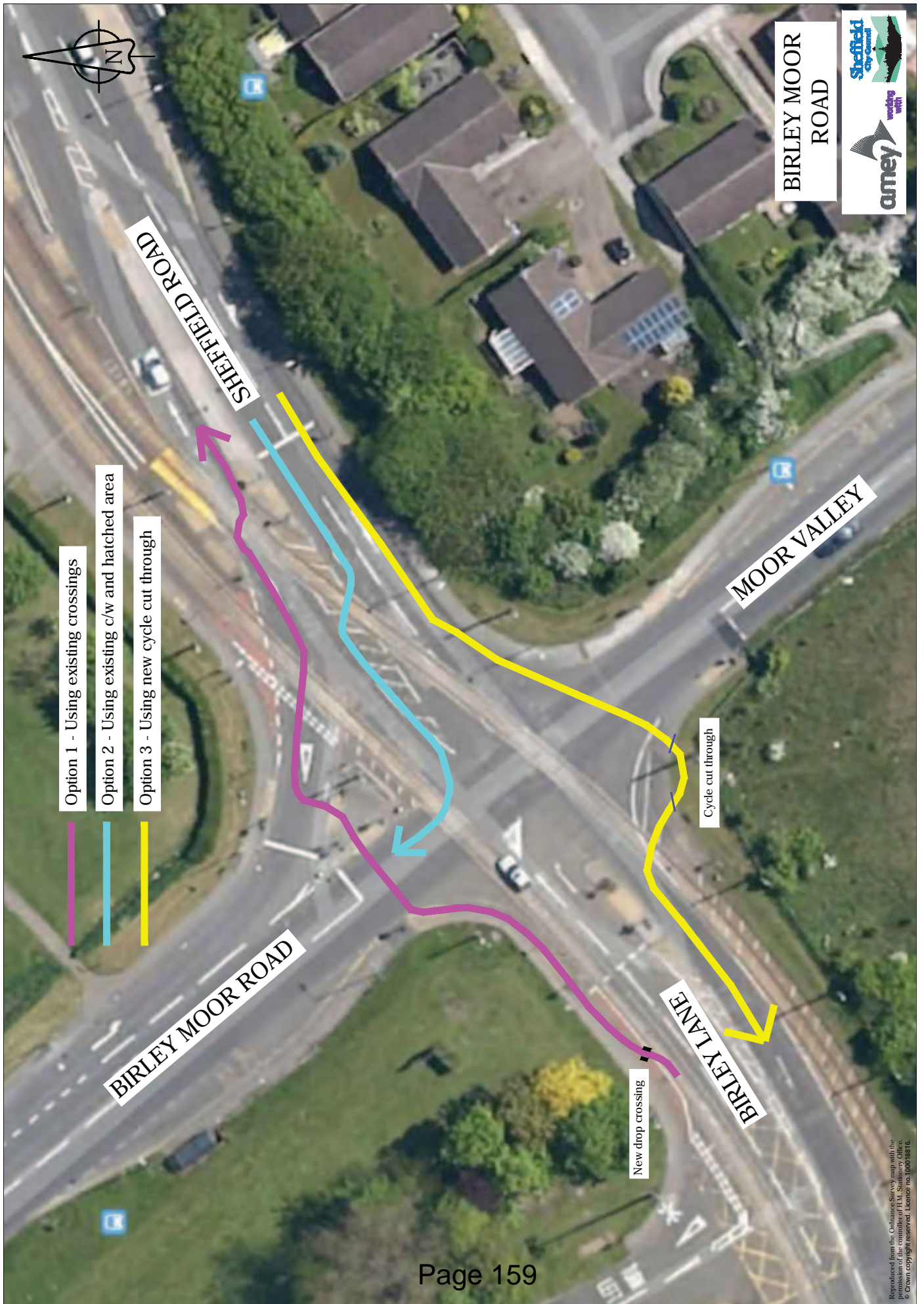
This arrangement would allow cyclists on Birley Lane travelling towards Sheffield Road to leave the carriageway on the left hand side in advance of the junction with Birley Moor Road via a dropped crossing onto the existing footway. This would require the footpath to be converted to a formal shared cycle/footway with signs and road markings. Cyclists would then cross Birley Moor Road using existing controlled crossings and use the junction mouth of Birley Moor Road and Sheffield Road to cross the tram tracks at the desired angle in order to re-join the carriageway. This option might require: widening of footway to cycle/footway, a new dropped crossing for cyclists only and signing and lining.

### **Option 2 – using existing carriageway and hatched area**

For this option, cyclists travelling Westbound on Sheffield Road and wanting to turn right into Birley Moor Road would need to use the offside lane. Cyclists would then cross the tram tracks and use the hatched area to wait to turn right on to Birley Moor Road. This option might require: some new road markings for cyclists.

### **Option 3 - using new cycle cut through**

For this option, cyclists travelling on Sheffield Road towards Birley Lane would need to use the nearside lane. Cyclists would then use the junction mouth of Moor Valley to join a cycleway cut-through to re-join the carriageway after the tram tracks. This option might require: a new dropped crossing, a short length of new cycle path through the existing verge and signs and road markings.



Option 1 - Using existing crossings

Option 2 - Using existing c/w and hatched area

Option 3 - Using new cycle cut through



Cycle cut through

New drop crossing

Reproduced from the Ordnance Survey map with the permission of the Ordnance Survey. © Crown copyright reserved. Licence no. 100018816.

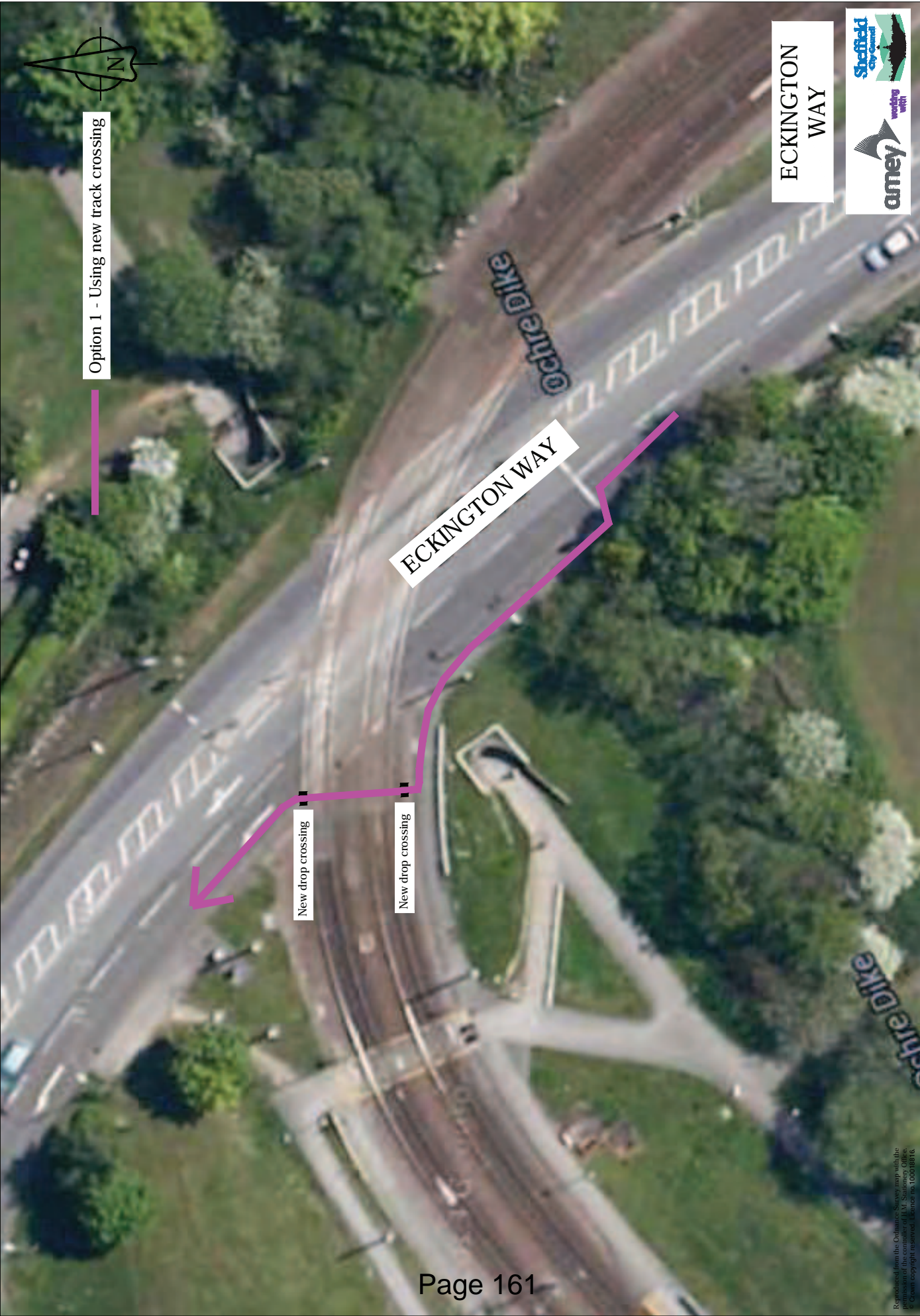
## Eckington Way – near Roundabout



### **Option 1 – using new track crossing**

For this arrangement cyclists would leave the carriageway on the left hand side at the traffic signals onto an existing footway. This would require the footpath to be converted to a formal shared cycle/footway with signs and road markings. Cyclists would then cross the tram tracks using a track crossing to re-join the carriageway. This option might require: a new track crossing facility, possible widening of footway to cycle/footway, signing and lining and two new dropped crossings.





Option 1 - Using new track crossing

ECKINGTON WAY

New drop crossing

New drop crossing

ECKINGTON WAY



## Fox Lane/White Lane

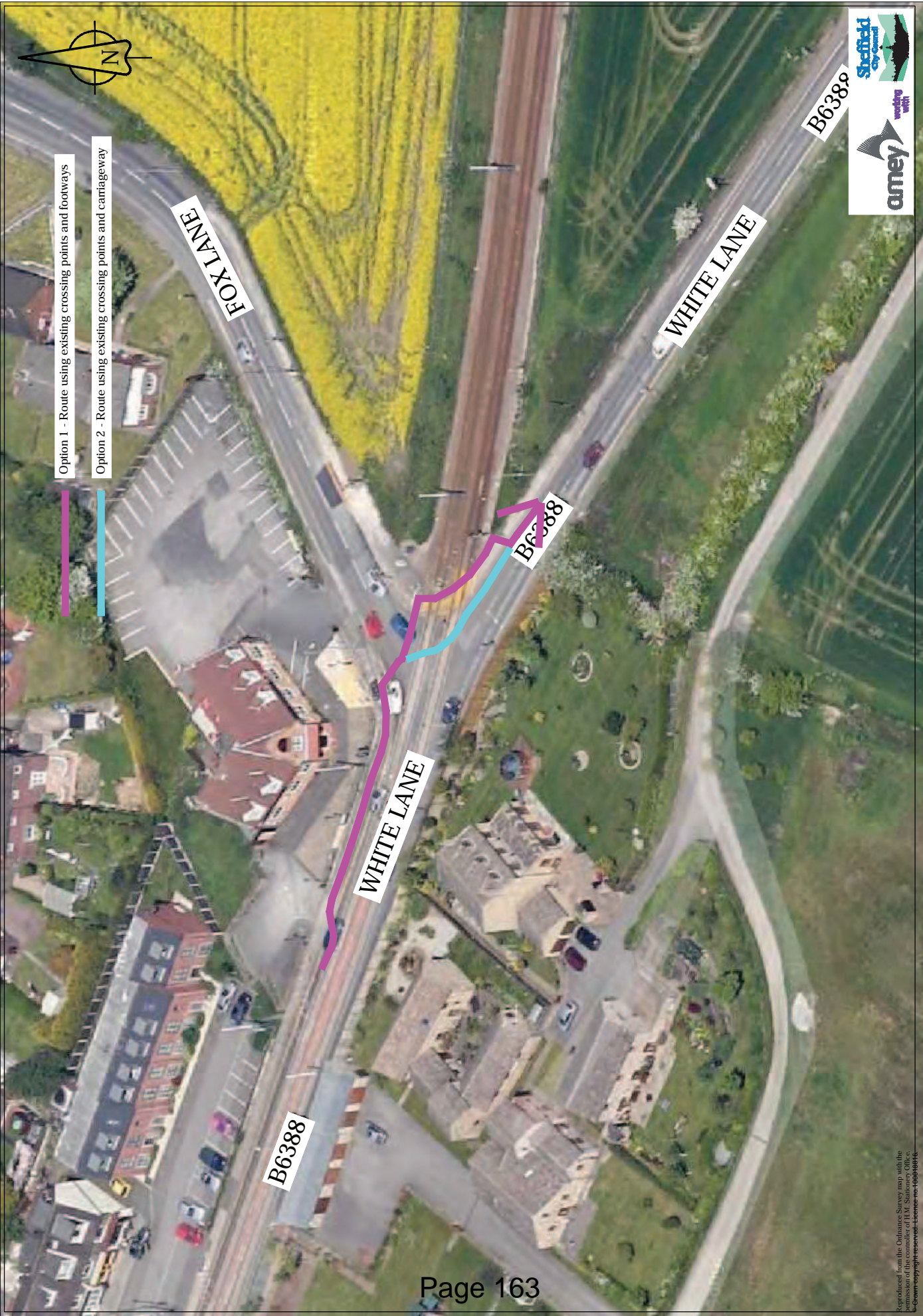


### **Option 1 – using existing crossing points and footways**

This option allows cyclists to leave the carriageway on the left hand side using the existing dropped crossing for the Restaurant Car Park and travel along the footway towards Fox Lane. This would require the footpath to be converted to a formal shared cycle/footway with signs and road markings. Cyclists could then cross Fox Lane, the tram tracks and return to the main carriageway using existing crossing points. This option might require: conversion of footway to shared use and signing and lining

### **Option 2 – using existing crossing points and carriageways**

This option is similar to Option 1 above, but cyclists would come back on carriageway at the junction to cross the tram tracks rather than use the existing footway track crossing.



Option 1 - Route using existing crossing points and footways

Option 2 - Route using existing crossing points and carriageway

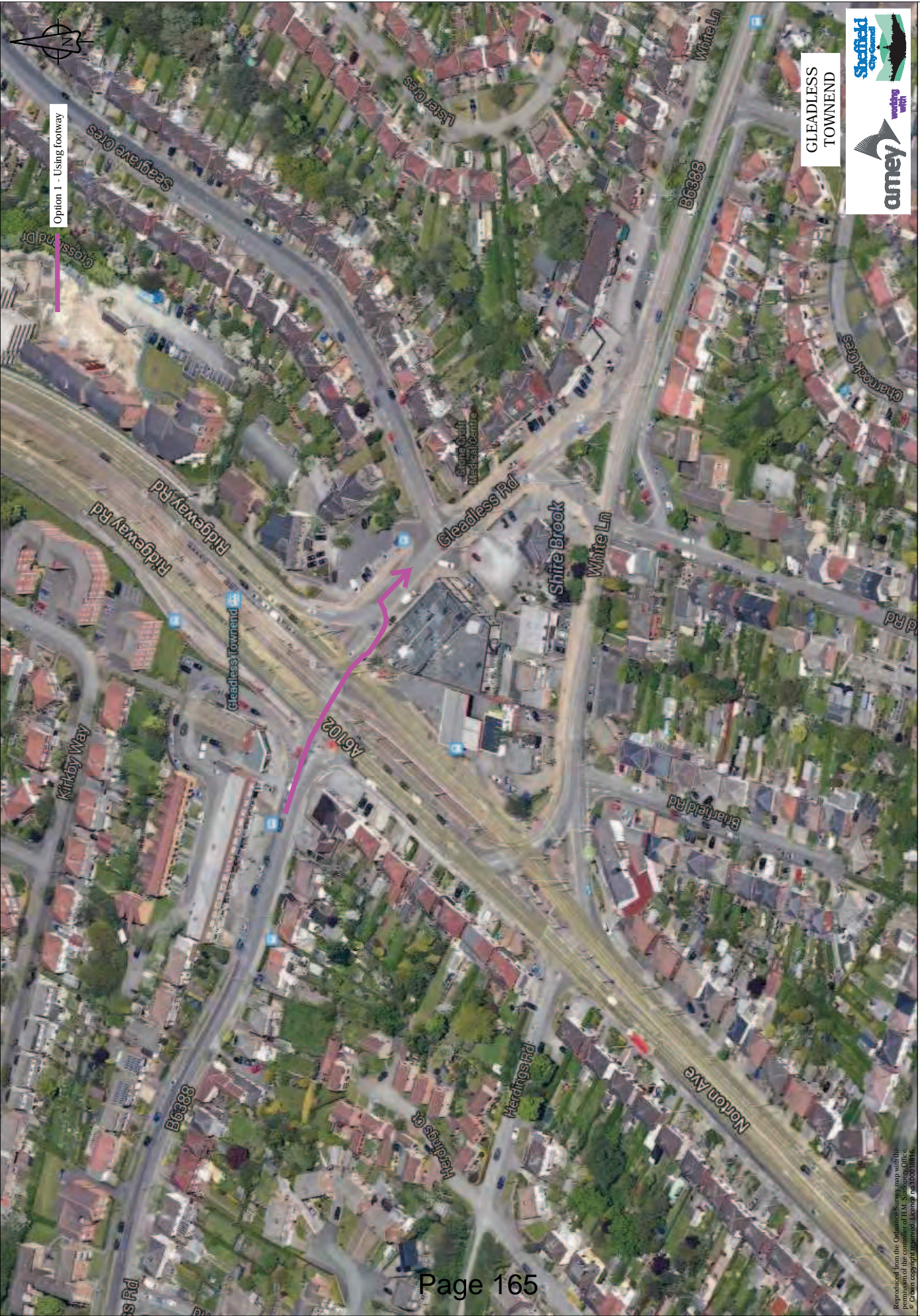


## Gleadless Townend



### **Option 1 – using existing footway**

Cyclists would need to use the offside lane on B6388 Gleadless Rd (West) to travel across Ridgeway Rd through the junction of Gleadless Townend. Cyclists would then join the existing footway at the start of Gleadless Road (East) using existing crossing points. The area used to travel through the junction would need to be indicated with signs and road markings. This option might require: designation of footway as shared use and signing and lining.



Option 1 - Using footway

GLEADLESS TOWNEEND



Reproduced from the Ordnance Survey map with the permission of the Ordnance Survey. © Crown copyright reserved. Licence no. 100088416.

## Granville Street

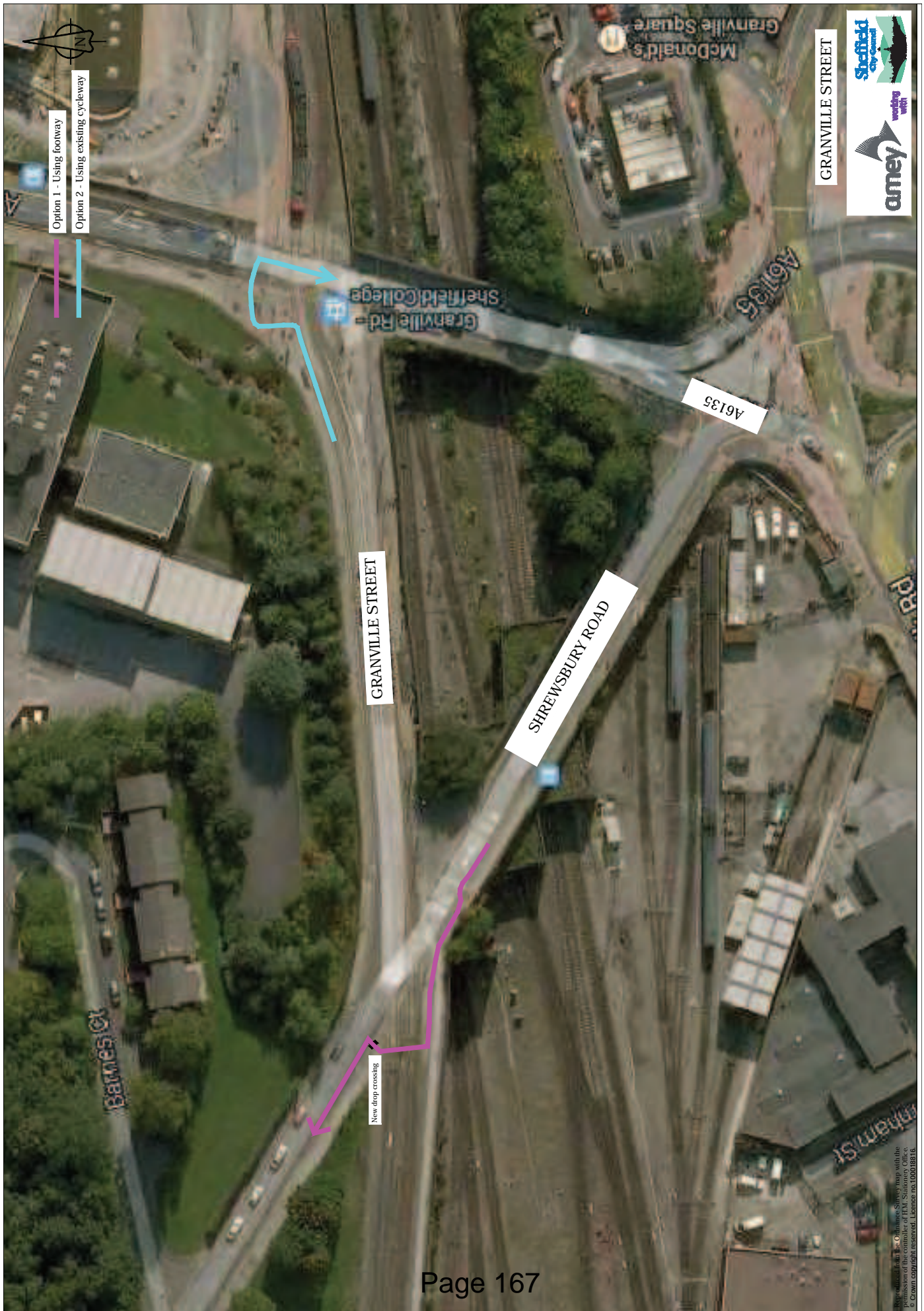


### **Option 1 – using existing footway**

This arrangement allows cyclists to leave the carriageway on the left hand side at the existing crossing point onto the footway. This would require this footpath to be converted to a formal shared cycle/footway with signs and road markings. Cyclists would then use the existing crossing to cross the tram tracks and re-join the main carriageway via a new dropped crossing close to the crossing point. There are minor level differences here between the crossing and carriageway that would need to be resolved. This option might require: a new dropped crossing, level adjustments and signing and lining.

### **Option 2 – using existing cycle facilities**

This option encourages cyclists to leave Granville St (riding Southbound) on the left-hand side using existing signal controlled cycle crossing facilities to make the right turn from Granville Street to Granville Road – as a G turn. No new facilities are required – but additional signs and road markings might be provided to assist cyclist doing this turn.



Option 1 - Using footway  
Option 2 - Using existing cycleway

GRANVILLE STREET

SHREWSBURY ROAD

GRANVILLE STREET

Granville Rd -  
Sheffield College

A6135

Barnes Ct

Granville Square  
McDonald's



Map data © OpenStreetMap contributors, Imagery © Mapbox, © Crown copyright reserved. Licence no. 100018816.

## Manor Top – Area A



### Option 1 – route using fast lane

This arrangement is for cyclists using the offside lane of Ridgeway Road. Cyclists can cross the tram tracks shortly after the tracks re-join the carriageway and join the central reservation. Cyclists would then continue along the central reservation and re-join the carriageway after the tram tracks. This option might require: signing and lining and two new dropped crossings.

### Option 2 – route using slow lane

This arrangement is for cyclists using the nearside lane of Ridgeway Road. Cyclists would leave the main carriageway on the left hand side via an existing dropped crossing to join the footway. This would require the footpath to be converted to a formal shared cycle/footway with signs and road markings. Cyclists would then re-join the carriageway using the hatching as a waiting area to give way to traffic. This option might require: signing and lining

## Manor Top – Area B

### Option 1 – using existing crossing points

This option allows cyclists travelling southbound on Ridgeway Road to leave the carriageway on the left hand side via an existing crossing point and re-join the carriageway after the junction on the A6135 giving way to traffic. This option might require: signing and lining

## Manor Top – Area C

### Option 1 – using existing side road

This arrangement allows cyclists to leave the main carriageway via the left hand side and travel along the existing side road. Cyclists would then re-join the carriageway at the end of the side road. This option might require: signing and lining





Option 1 - Route using Slow Lane



RIDGEWAY ROAD



MANOR TOP (A)

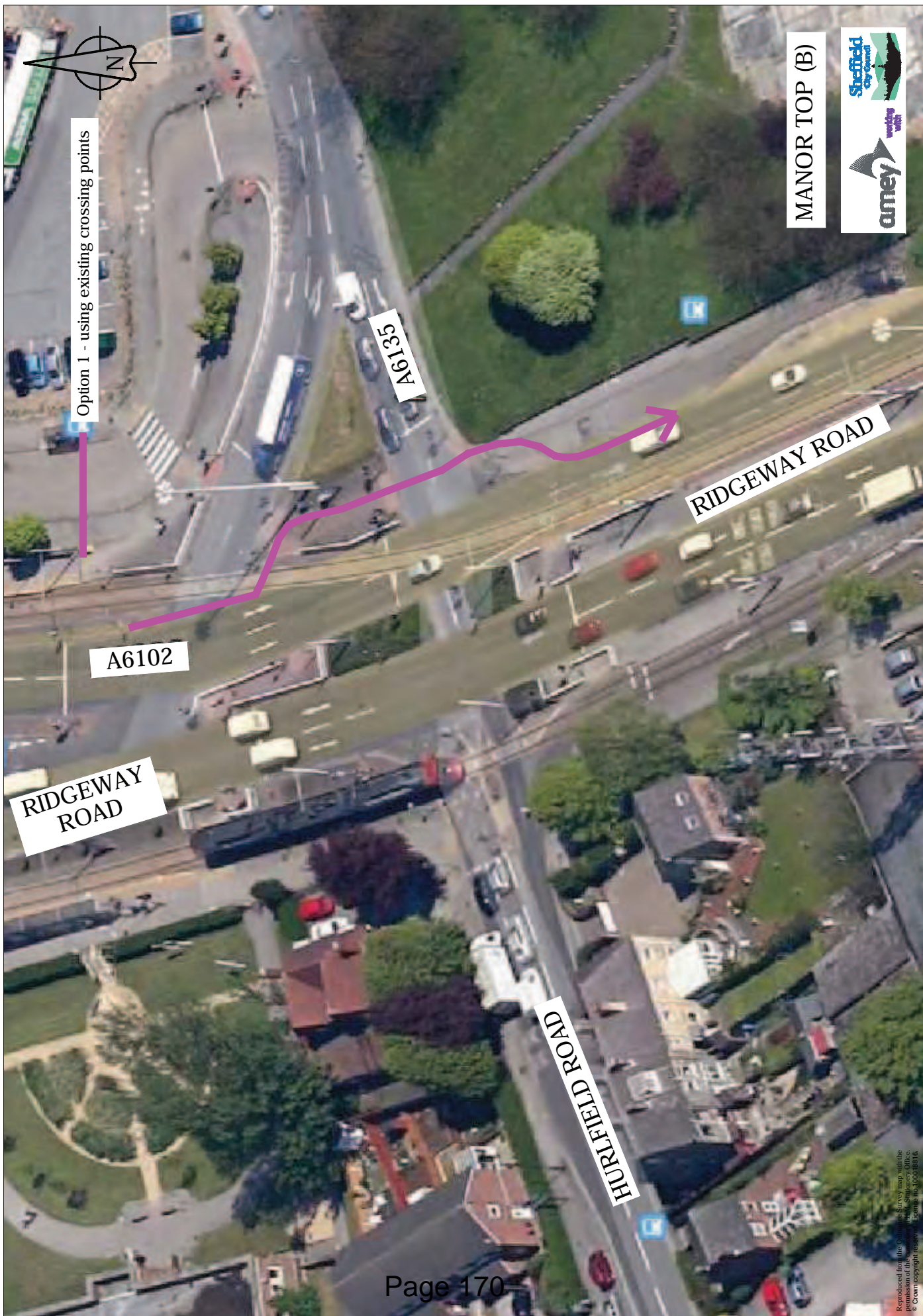


A6102

HURFIELD ROAD

RIDGEWAY DRIVE

Reproduced from the Ordnance Survey map with the permission of the controller of Her Majesty's Stationery Office. Crown copyright reserved. Licence no. 100049166.



Option 1 - using existing crossing points

A6135

A6102

RIDGEWAY ROAD

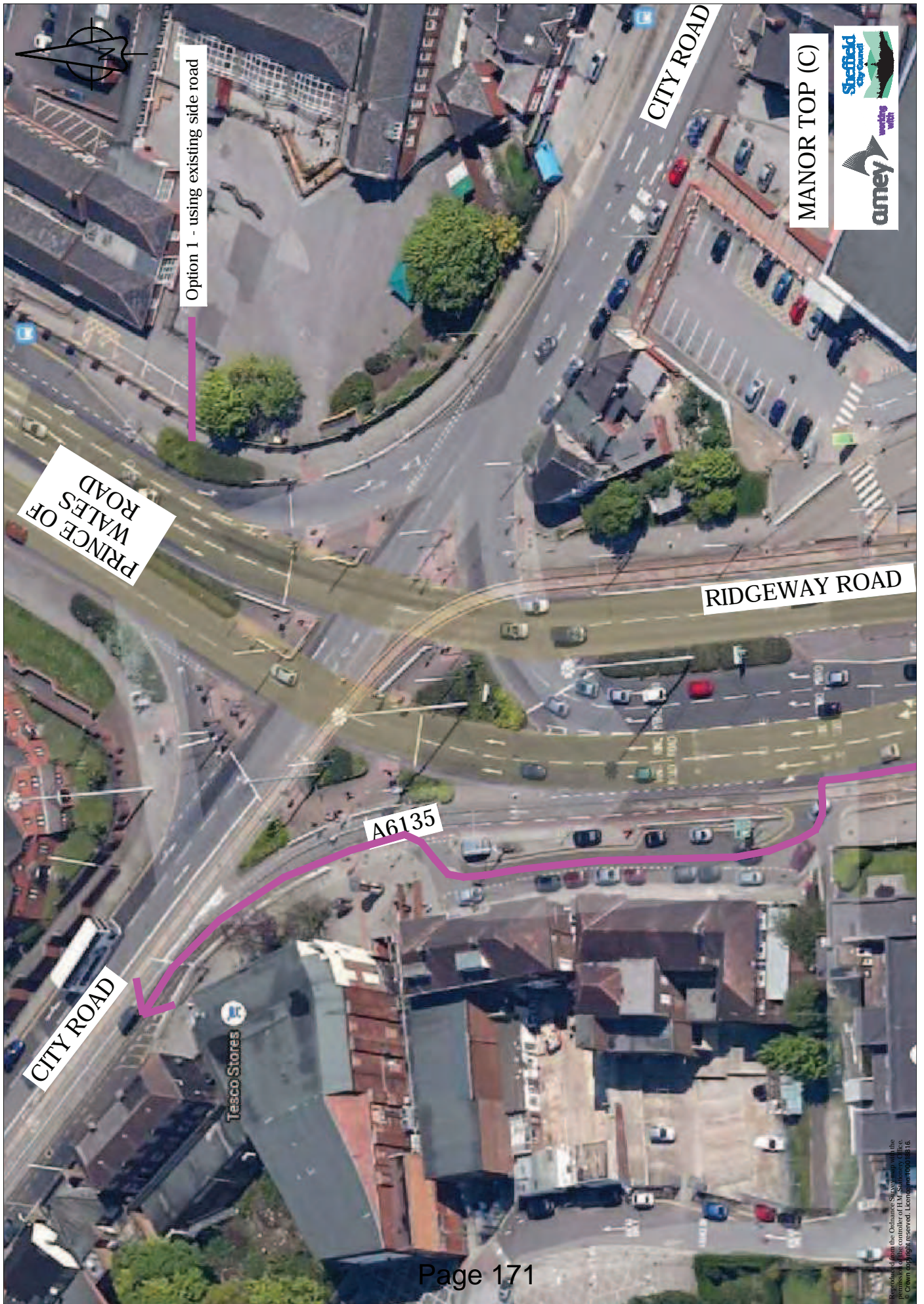
HURFIELD ROAD

RIDGEWAY ROAD

MANOR TOP (B)



Reproduced from the Ordnance Survey map with the permission of Ordnance Survey. © Crown copyright reserved. Licence No. 100088316



Option 1 - using existing side road

PRINCE OF WALES ROAD

CITY ROAD

MANOR TOP (C)

RIDGEWAY ROAD

A6135

CITY ROAD

Tesco Stores



Reproduced from the Ordnance Survey map with the permission of the Ordnance Survey. All rights reserved. © Crown copyright reserved. Licence No: 100018116.

## Middlewood Road



### **Option 1 – using front of footway**

This arrangement allows cyclists travelling southbound on Middlewood Road to leave the main carriageway on the left hand side in advance of the signalised junction and cross the tram tracks using the existing crossing point. A small section of the existing footpath would need to be converted to a formal shared cycle/footway with signs and road markings. Cyclists would then travel along the back footpath closest to the residential development. This would also need to be converted into a formal shared cycle/footway with signs and road markings. Cyclists would re-join the carriageway after the tram tracks. The option might require: new dropped crossing for cyclists only and signing and lining.

### **Option 2 – using back of footway**

This arrangement allows cyclists travelling southbound on Middlewood Road to leave the main carriageway and cross the tram tracks using the bell mouth of the access road to the tram car park. Cyclists would then travel along the front footpath closest to the carriageway. This would need to be converted into a formal shared cycle/footway with signs and road markings. To cross the second set of tram tracks cyclists would use the bell mouth of the access road to the residential development before using the existing footpath to re-join the carriageway. The option might require: new dropped crossing for cyclists only and signing and lining.



Option 1 - Using front footway

Option 2 - Using back footway



MIDDLEWOOD ROAD



New drop crossing

New drop crossing






MIDDLEWOOD ROAD




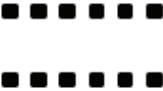
HARRIS ROAD

Reproduced from the Ordnance Survey map with the permission of the Ordnance Survey. All rights reserved. © Crown copyright reserved. Licence no. 100088316.

## APPENDIX 6

### TYPICAL WORKS COSTS

<p align="center"><b>SIGNS</b> (all on new posts)</p>	<p align="center"><b>COST (£)</b> (including post)</p>
<p>Direction for pedal cycles</p>  <p>Diagram No. 2601.1</p>	<p align="center">£140</p>
<p>Route for use by pedal cycles and pedestrians only</p>  <p>Diagram No. 956</p>	<p align="center">£145</p>
<p>Pedal cyclists to re-join main c/w at end or break in cycle track/route</p>  <p>Diagram No. 966</p>	<p align="center">£165</p>
<p>Direction at a junction for pedal cycles including destination</p>  <p>DfT approval required</p>	<p align="center">£220</p>
<p>Advance Direction for pedal cycles including destination</p>  <p>DfT approval required</p>	<p align="center">£220</p>

<p align="center"><b>SIGNS</b> (all on new posts)</p>	<p align="center"><b>COST (£)</b> (including post)</p>
<p>Route for pedal cycles avoiding tram tracks – or a similar sized sign</p>  <p>DfT approval required</p>	<p align="center">£290</p>
<p>Warning – slippery rails (tram tracks) on backing board – or a similar sign with plate</p>  <p>DfT approval required</p>	<p align="center">£390</p>
<p align="center"><b>ROAD MARKINGS</b></p>	<p align="center"><b>COST (£)</b></p>
<p>Cycle lane, track or route</p>  <p>Diagram No. 1057</p>	<p align="center">£25</p>
<p>Cycle crossing</p>  <p>DfT approval required before new TSRGD 2015.</p>	<p align="center">£2.50 per 'foot'</p>



## Red Areas / White Line Hatchings - comparative costs

Basic material costs:

### White Lines

100mm white lines:	£1.80 / metre
150mm or 200mm white lines:	£2.06 / metre

**Red Surfacing** ~ from around £10/m<sup>2</sup> (up to around ~£210/m<sup>2</sup>)

This is very dependent on the size of the area to be surfaced and the time required for the works (as plant hire and specialist staff costs are considerable) - and the condition of the existing surface (which may need to be treated or planed out before being overlaid, to ensure a good bond with the road surface).

All the above costs are subject to additional costs for traffic management, out of hours working (if required) and preliminaries (depending on what staff and equipment would be required on site). However red surfacing would almost certainly require overnight working alongside Supertram tracks, whereas white lining would be a quicker operation and could *possibly* be done during the day in some areas – with Supertram staff banks man protection.

However – to give a comparison illustration of say a 200 metre length of existing red edge surfacing – about 1 metre wide (which is typical on a straight section of tramway) – using a £25/m<sup>2</sup> basic rate for red surfacing for a reasonable length of working area:

### Example: Basic costs for an edge area on a 200 metre length of road

**1) Red surfacing and solid edge line:**

Red surfacing: 200m x 1m x £25 = £5000

Edge line: 200 x £1.80 = £360

**Total** (basic material and installation costs): **£5360**

**2) White Lines only – Hatching:**

Hatch lines every 3m: 67 x 1m x £2.06 = £138

Edge Lines (4m and 2m gap): 134 x £1.80 = £241

**Total** (basic material and installation costs): **£379 \*\*\***

\*\*\* It is assumed that any previous red surface in this area does **not** need to be planed out and re-surfaced prior to installing the hatched line markings.

This highlights that the material cost differences are very significant, and these differences will be exacerbated once the cost of Traffic Management and Works Preliminaries are taken into account. Although these additional costs are very site specific, they are likely to be much greater for the installation or replacement of red surfacing.

## Typical Highways Civils works costs

CIVILS	COST
Uncontrolled (buff) dropped crossing – for pedestrians (with tactile paving)	£2000 a pair
Controlled (red) dropped crossing – for pedestrians (with tactile paving)	£4000 a pair
Narrow Dropped crossing – for cycles (without tactiles)	£2000 a pair
Widening of footway	£420 per linear metre (2m wide)
Widening into verge	£380 per linear (2m wide)

### NOTES

- Variations in all the above costs are very site specific
- Design, planning and coordination of schemes is not included above
- All the above costs also **exclude**:
  - Preliminaries for site works (setting out, health and safety, welfare facilities, etc.)
  - Traffic Management requirements for installation works
  - Out of hours working (late night or weekend)
  - Works to adjust or re-locate the equipment of Statutory Utilities in carriageways, footways and verges
  - Electrical servicing of signs
- A budget contingency/allowance is suggested of an additional 30% for these items for schemes involving civils works; and around 50% for schemes involving traffic works (signals, signing and lining) only. This excludes design and Road Safety Audit fees which will be specific for each scheme.

# APPENDIX 7

## Traction Circle Theory (or The Traction Zone)

A visual representation of available traction

Cyclists should be aware there is a limit placed on the amount of available traction that they have whilst cycling on any road surface. They should also know that if you happen to stray past that limit then the consequences are often not so good, and you are likely to skid or slide on the road surface.

However, while we know that the limit is there and we don't want to exceed it, for many it will feel like some vague area that they aren't really familiar with and don't know at what point it exists.

To combat this lack of clarity and give riders an idea of what the traction limit looks like, there is a commonly used visual representation of the traction zone (also known as the traction circle) that demonstrates how we can best use available traction.

As the capabilities of a cyclist to accelerate very quickly is limited, it is helpful to explain this concept in relation to motorcycles first – even though the concept is identical for bicycles and works in the same way.

What is it?

As the picture to the right shows, the traction circle is shown as a simple graph, with traction being shown as the accelerative force acting against you, the bike and the tyres in every direction.

Now, for a lot of people the only known definition of acceleration will be the 0-60 time of their car, but here we are talking about the measurement of acceleration felt as weight – known as g-force, or G for short.

So just like when accelerating in a straight line, you are also experiencing this accelerative force (g-force) during braking and turning too. This common relationship handily allows us to plot these accelerative forces on the same graph.

For a competent motorcyclist on a good motorcycle with good tyres on a good road surface, the maximum accelerative force that can be applied in any direction will be around 1G. In this case, 1G will represent the outer limit of the circle on the graph.

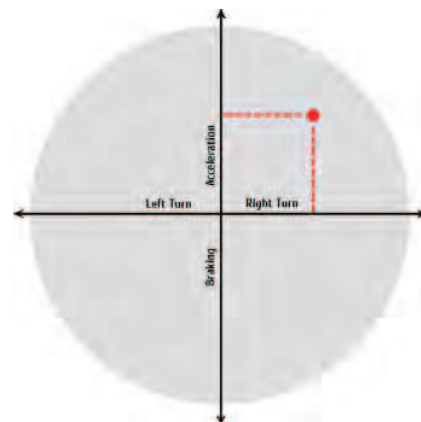
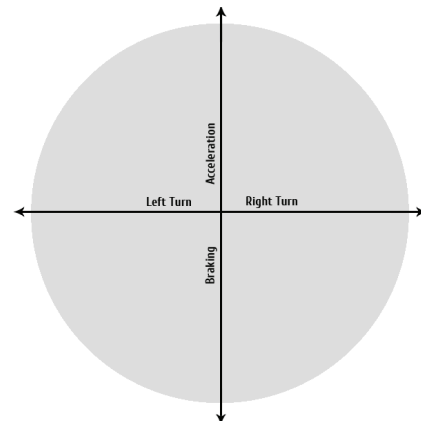
Using the graph

For example then, if you imagine accelerating hard in a straight line on a 1000cc bike, you would find yourself plotted on the graph near the top of the vertical line. Similarly, braking hard in a straight line would be plotted near the bottom of that same axis.

At maximum lean in a right hand turn, as you would expect, you would see yourself plotted out to the right hand edge of the circle on the horizontal line.

It's only once you start using a combination of acceleration or braking with turning that you'll see the point come away from either axis on the graph.

The picture above shows what the graph would look like if you were at moderate lean to the right and applying moderate acceleration at the same time.



Looking at this representation then you can quickly see what it is that causes riders to lose traction.

Imagine another rider at maximum lean in a right hand turn, the graph to the right shows exactly what happens when they accelerate too quickly in mid turn.

They step out of the traction zone because they're asking the tyres to deal with too much accelerative force. Equally, the same could happen when starting to corner too quickly.

Similarly, if you're hard on the brakes in a straight line and you try to turn, thereby adding lateral g-force to the tyre, this will more than likely exceed that 1G limit and again, you would lose traction.

It's clear then that your job as a rider is to make sure that you stay within this traction zone at all times by keeping the force acting against the tyres under that maximum 1G.

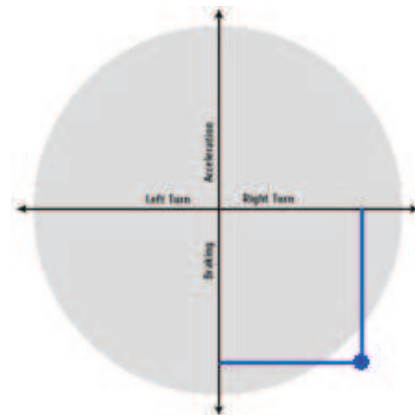
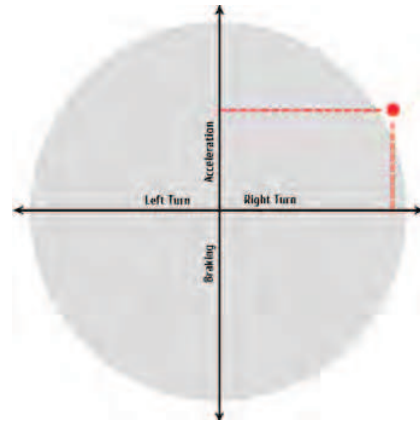
In motorcycle racing, the primary objective is to stay within but as close as possible to the outer boundaries of the circle – to maximise speed with cornering where necessary without losing control.

It is worth noting that the traction available changes depending on the surface that you are riding over. In effect, if you cross a more slippery surface, the Traction Circle becomes smaller, and it is easier to lose control and move outside the Traction Zone.

The same principles apply for cyclists on roads and other surfaces. For cyclists, acceleration is less likely to be an issue, but excessive combinations of braking and leaning/cornering can push the cycle tyres outside the traction circle, (in the lower half of the circle) so that the cyclist will slide and lose control.

Therefore considering the Traction Circle theory in reverse – it is clear that to minimise the risk of cyclists losing control when riding over slippery surfaces, they should try to stay as close to the centre of the Traction Circle as possible. This means that avoiding braking, accelerating and leaning/cornering are all helpful to maximise traction even when the traction available is very limited.

This matter could be significant when cycling over ice or over smooth steel, such as over tram rails on-street, and could be a significant factor in some loss of control incidents by cyclists on tram tracks.

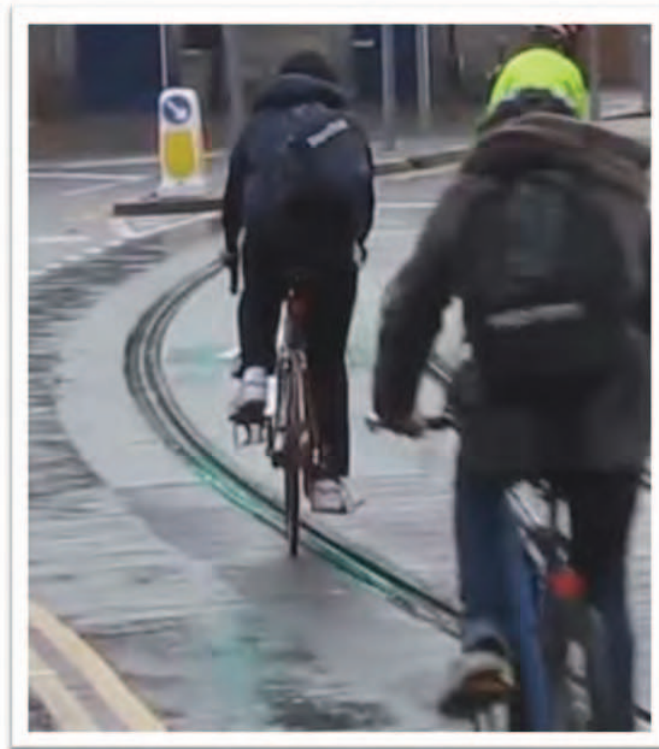


Note: this Appendix includes text and diagrams which has been extracted from a web site, with the permission of the author <http://biketrackdayshub.com>

**APPENDIX 8**

**Cycle / Rail Crossing Behaviour**

**A preliminary analysis**



## 1. General Principles

- The stability of a bicycle in motion is affected by various factors. Most of these are intrinsic to the design of the bicycle, for example:
  - The inclination of the steering axis.
  - The 'trail', i.e. the horizontal distance from the intersection of steering axis and ground to the centre of the tyre contact patch.
  - The wheelbase
  - The diameter of the wheel and tyre (this has an effect on the ease with which the tyre rides over obstacles, and also on the trail measurement)

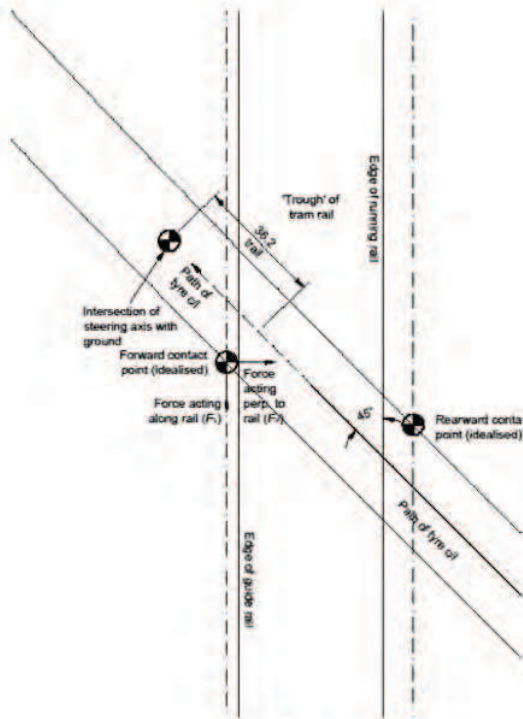
In normal riding, the inclination of the steering axis means that any steering position other than dead centre requires the centre of mass to be raised. This is what gives bicycle steering its self-stabilising quality as the system naturally seeks its lowest point - it can be thought of as being in a rut (in a geometrical rather than physical sense) or 'potential energy well'.

Other factors can be described as operational or environmental, for example:

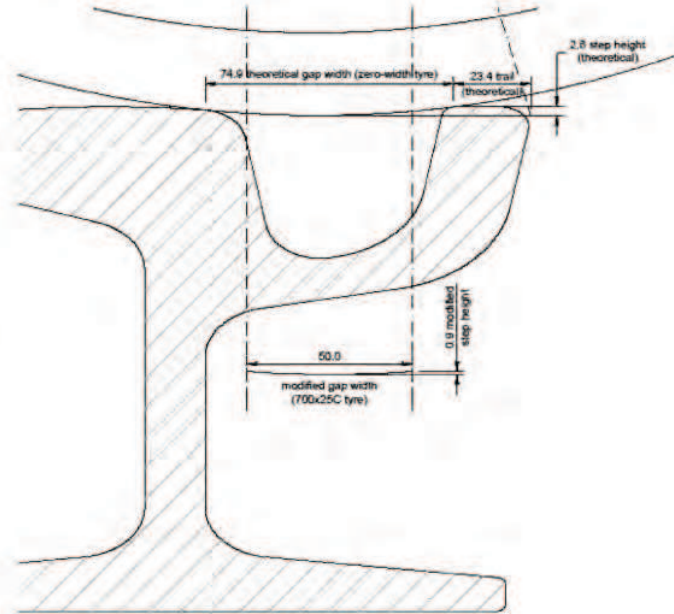
- The braking force being exerted
  - The 'lean angle' applied when cornering, and the lateral force which results
  - Any acceleration applied through the rear tyre
  - The coefficient of friction,  $\mu$ , between tyre and road
- The value of  $\mu$  governs the amount of force available for traction of all kinds; braking, acceleration and cornering. The resultant of these forces can be found by Pythagoras or by constructing a 'traction circle'. For example, if 500N are available for traction and the action of cornering at a certain speed demands 400N, there is a maximum of 300N available for braking/ acceleration. Clearly it is best to keep these forces to a minimum when making the transition between wet asphalt ( $\mu=0.7$ ) and wet steel rails ( $\mu=0.3$ ), as even a generous safety margin on asphalt can give way to sliding failure on steel!
- The action of crossing a tram rail can also destabilise bicycle steering, leading to the 'guiding effect' described by some injured parties, in which the front wheel is guided into the trough of the tram rail. This can happen in the following ways:
    - The change from the rearward to the forward contact point will momentarily shorten the 'trail' and make the steering less stable. As the crossing angle becomes shallower, the distance between these contact points increases and the decrease in trail is more pronounced.
    - Contact with the forward edge of the rail also destabilises the steering, since the system seeks the 'path of least resistance' and as the height through which the system must raise itself approaches the depth of the 'potential energy well' the self-stabilising effect of the steering diminishes.
    - The first point of contact with the obstruction is off-centre. This creates a moment about the steering axis which can be beneficial or detrimental according to the crossing angle.

## 2. Wheel Behaviour during Rail Crossing

These effects will now be examined in greater detail. Let us look at what happens at the instant when the tyre is in contact with both running rail and guide rail simultaneously (i.e. it is bridging the gap). The diagram below shows a 25mm (racing-type) tyre crossing a nominal 41mm gap at an angle of 45°:



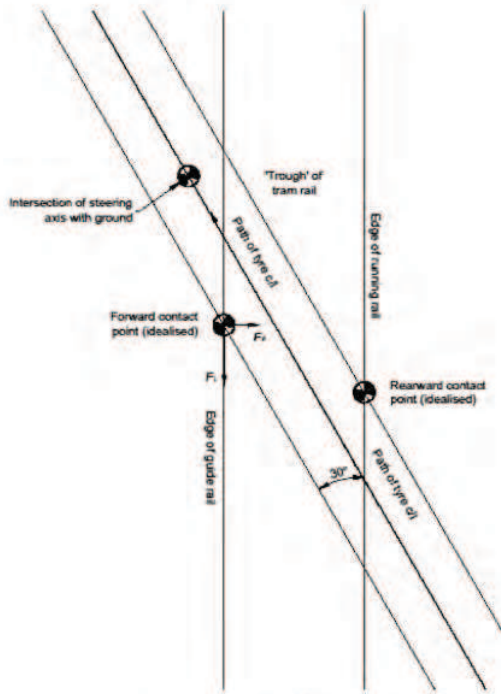
**Fig.1a**  
(Crossing tram track from RHS at 45deg)  
Scale 1:2



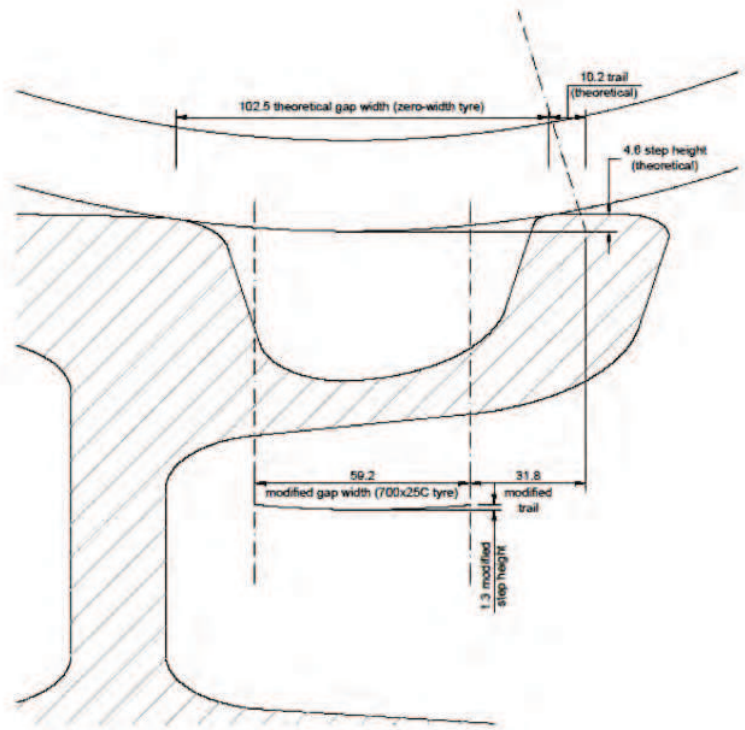
**Fig.1b**  
(Section through plane of bicycle wheel, crossing tram track at 45deg)  
Scale 1:2

By inspection the first point of contact with the guide rail will not be at the centre of the tread but at some point towards the edge of the tyre. The exact position of this point will depend on the diameter of the tyre cross-section and the amount by which the tyre has dropped into the gap prior to contact. This in turn is dependent on wheel diameter, crossing angle and tyre width again.

Of course, in reality the contacts are not idealised points but patches of a significant size. For a racing tyre under normal loading a typical size for the contact patch might be 90x8mm. However this is for a tyre on a flat surface; in the case of the tram rail the contact is against a sharply curved surface and one might expect considerable deformation of the tyre even at the relatively high pressures typical of these tyres. It seems that this would have the effect of broadening and considerably shortening the contact patch into something more like a circle.

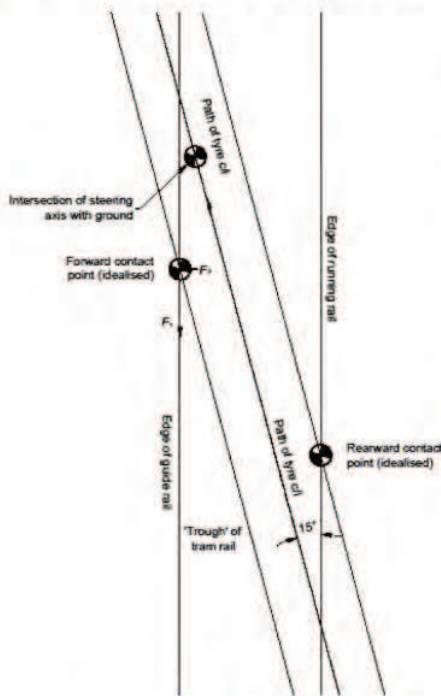


**Fig.2**  
(Crossing tram track from RHS at 30deg)  
Scale 1:2

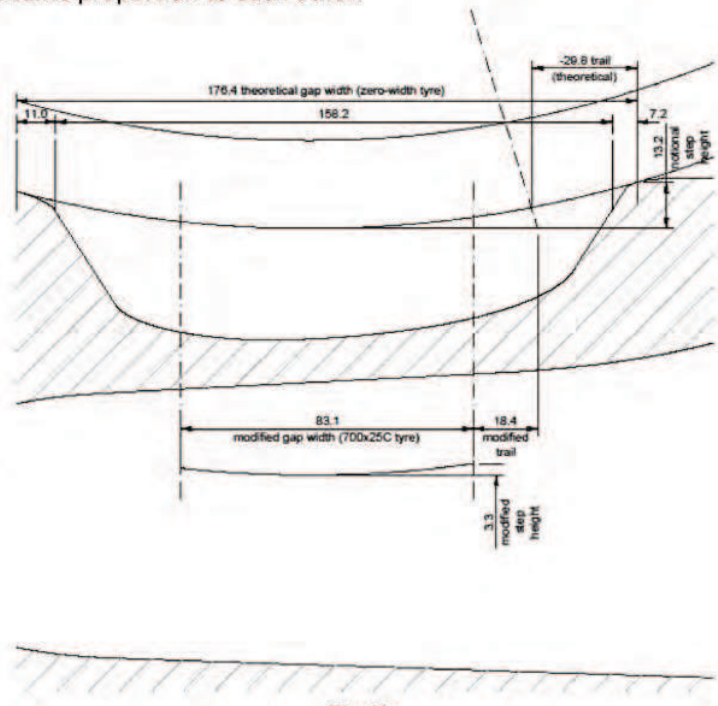


**Fig.2b**  
(Section through plane of bicycle wheel, crossing tram track at 30deg)  
Scale 1:2

Having dropped into the gap, the tyre must then climb over the rail edge if it is to maintain its original course. So the rail edge represents an obstruction which causes a certain amount of rolling resistance in the direction of the tyre centreline. This can be resolved into reactions along and perpendicular to the rail; these are labelled FL and FP in the diagram. So FL represents the tendency to slide along the rail and  $\mu FP$  then gives the resistance to sliding and also the traction available to climb the rail ( $\mu$  is approx. 0.3 for rubber/wet steel). NB the rearward contact point will give rise to 'drag' forces which are smaller (because there is no obstruction) but in the same proportion to each other.



**Fig.3**  
(Crossing tram track from RHS at 15deg)  
Scale 1:2



**Fig.3b**  
(Section through plane of bicycle wheel, crossing tram track at 15deg)  
Scale 1:2



It is also noticeable that both reactions act about the steering axis; FP acts anti-clockwise, tending to force the wheel into the 'face' of the rail edge, helping it 'dig in' and climb, while FL acts clockwise and tends to turn the wheel towards the trough of the rail. Both effects seem to be self-perpetuating in that the steepening of the crossing angle increases FP in turn, while the decrease in crossing angle due to FL serves to increase that force (and with it the tendency to slide and/or settle into the trough).

It follows that whichever of these is dominant at the first instant of contact should remain so; and from this that there is very little that can be done if the tendency to slide initially outstrips the wheel's ability to climb. Needless to say this is very much affected by whether the steel rail is wet or dry!

Of course, up to a certain point these factors are too slight to have an effect. This could be because they are too gentle (and hence slow-acting) to significantly disturb the path of the bike; another explanation might be that the elasticity of the tyre provides enough of a 'kick' to get over small obstacles. In practice it can be safe to ride over tram tracks at angles of 60° or less in dry rail conditions. So at what point do these destabilising forces become significant?

### 3. Conclusions

The oft-quoted ideal crossing angle of 90° is not only difficult to achieve in practice, it could put riders in more danger, not less, if they brake or lean (or both!) in their attempts to achieve this. It seems better to accept a modest crossing angle of around 60°, but to cross upright and at a steady speed, since the mechanisms which seem to produce the 'guiding effect' do not appear to become significant until well below this figure.

It is not necessary to 'fall into the rut' to experience considerable destabilising effects, especially on the front wheel, so it follows that large MTB-style tyres are no guarantor of safety; it is however true to say they are less susceptible to these effects. More detailed conclusions are as follows:

- Fat tyres effectively shorten the distance between forward and rearward contact points, thus reducing the effective gap at small crossing angles (and with it the 'step height' that must be overcome). Bicycles designed for this type of tyre generally have more stable steering geometry in any case.
- Large-diameter wheels also reduce the effective 'step height' since they will drop less far into a given gap, *and* experience less rolling resistance from an obstruction of a given size.
- From the above one might draw the fairly obvious conclusion that big, fat tyres (e.g. 29x2.35") are less susceptible to the effects described above. However the converse is that small, thin tyres (such as those found on Bromptons, Moultons and the like) may suffer loss of stability at much more modest crossing angles. It remains to be seen whether wheel diameter is actually a more significant variable than tyre width.
- One final cautionary note concerns the phenomenon of *rear-wheel slides*. One explanation for this could be careless braking/ acceleration but this cannot account for all cases. It is known that when negotiating a given curve, the rear wheel turns through a wider radius than the front. Therefore, when taking a curved path across tram rails, the rear wheel crosses at a narrower angle than the front. Since the rear is not steerable the 'guiding effect' *per se* does not apply, but the wheel's inability to ride up over the rail at acute angles could instead cause it to slide, particularly if traction is limited by the bicycle leaning or by moderate pedal pressure being applied.

## APPENDIX 9

Sheffield University – Student Project Brief

Develop a Solution to Cyclist Accidents on Tram Tracks

# Develop a Solution to Cyclist Accidents on Tram Tracks



Your task:

- Think outside the box to develop a solution to this problem that could be implemented in Sheffield
- Prototype and test the solution – in the lab and/or the field

Problem:

- Cyclists can fall when having to cross tram tracks
- Bike wheels can slip on the rail and then get caught in the groove



## APPENDIX 10

### Links to Web sites and Internet Resources

## Guidance

The Highway Code - Section 4 - Tramways (300 to 307)

<https://www.gov.uk/road-works-level-crossings-tramways-288-to-307/tramways-300-to-307>

## Reports on other Tramway Systems and Design Guidance

BICYCLE INTERACTIONS AND STREETCARS: Lessons Learned and Recommendations (Portland, USA):

[http://www.altaplanning.com/wp-content/uploads/Bicycle\\_Streetcar\\_Memo\\_ALTA.pdf](http://www.altaplanning.com/wp-content/uploads/Bicycle_Streetcar_Memo_ALTA.pdf)

Streetcar Tracks and Cyclist Safety (Toronto, Canada):

<http://www.toronto.ca/legdocs/mmis/2012/pw/bgrd/backgroundfile-51593.pdf>

Best practices in providing bicycle facilities in streetcar corridors (Arlington County, Virginia, USA; Toole Design Group):

<https://www.mwcog.org/transportation/activities/tlc/pdf/ArlBike-PPT.pdf>

Cycling and the Edinburgh tramway:

<https://www.yumpu.com/en/document/view/11232924/0711-23-cyclingandtheedinburghtram-hansreport-proofread1/3>

LRT urban insertion and safety: European experiences

<https://drive.google.com/file/d/0BxoI3J-J1EVGUUI0YV82ZDVwejQ/view?pli=1>

Broadway Bikeway, Seattle – Presentation to Stakeholders

<http://www.scribd.com/doc/52895209/transportation20110412-5b>

COST TU1103 – European

<http://www.tram-urban-safety.eu/>

## Cycle / Track Accidents and Incidents

<http://ilovebikingsf.com/2013/07/12/i-crashed-sf-train-tracks/>

[http://www.stmichaelshospital.com/media/detail.php?source=hospital\\_news/2012/20121026\\_hn](http://www.stmichaelshospital.com/media/detail.php?source=hospital_news/2012/20121026_hn)

<http://tinyurl.com/o2ee67j>

<http://tinyurl.com/ka2fn2e>

<http://tinyurl.com/l6hhevc>

<http://tinyurl.com/p535mpy>

<http://tinyurl.com/ny3dan9>

## Theoretical

- Bicycle Dynamics

<http://bicycle.tudelft.nl/schwab/Bicycle/>

<http://bicycle.tudelft.nl/benchmarkbicycle/>

<http://rspa.royalsocietypublishing.org/content/463/2084/1955>

<http://cozybeehive.blogspot.co.uk/2009/09/dynamic-stability-of-bicycle-design.html>

<http://cozybeehive.blogspot.co.uk/2007/11/mathematical-bicycle-model-to-end-all.html>

- Traction Circle

<http://www.auto-ware.com/setup/fc1.htm>

<http://www.auto-ware.com/beckman/phors07.htm>

[http://www.formula1-dictionary.net/traction\\_circle.html](http://www.formula1-dictionary.net/traction_circle.html)

<http://www.motoiq.com/MagazineArticles/ID/2026/The-Physics-of-Tires.aspx>

<http://www.stevemunden.com/friction.html>

## Design Arrangements on other systems

Bike Sneaks:

<http://greatergreaterwashington.org/post/16648/a-bike-sneak-helps-bicyclists-cross-streetcar-tracks/>

## Signing and Road Markings

## Track Groove fillers and similar systems

veloStrail: <http://www.strail.de/index.php?id=197&L=1>

## Cycle Group web sites and forums

<http://www.cyclesheffield.org.uk/2015/01/23/consultation-cyclists-safety-on-the-tram-tracks/>

<http://www.tramcrash.co.uk/>

<http://www.spokes.org.uk/documents/public-transport/tram/>

<http://www.greatgasbeetle.com/cycling-and-the-sheffield-tram-network-a-match-made-in-hell/>

<http://www.birminghamcyclist.com/video/safe-tram-line-design>

<http://www.boards.ie/vbulletin/showthread.php?t=2056423737>

[https://www.facebook.com/SturzStelle/timeline?ref=page\\_internal](https://www.facebook.com/SturzStelle/timeline?ref=page_internal)

<http://citycyclingedinburgh.info/bbpress/topic.php?id=14264&page=4>

# APPENDIX 11

## Additional Work to Progress (non-site related issues)

During the course of this study, various actions have been recommended that do not relate to possible works on site. Not all of these might be possible to fund initially, but all might be considered for future work. These are:

- Improve the collection, collation and analysis of accident data for cyclists – both on and off the tramway in Sheffield – by:
  - Providing a web page on the Sheffield City Council web site where cyclists can advise the Council about new cycle accidents that they have had, which could be both tramway and non-tramway related. A link to this web page could be added to other public and cycle group web sites.
- Provide up-to-date information on riding safely near and across the tram tracks. This might include some site specific information, and might be in various forms (leaflets, training for cyclists, web site pages). Later this might include new advice based on further research into this matter.
- Consider the provision of new training facilities for crossing tram tracks – off the Supertram route.
- Investigate and provide more information (on various media) on alternative cycle routes which avoid riding along or across the tramway.
- Carry out or sponsor additional research into factors affecting the safety of cyclists crossing tram tracks, in order to improve the advice that can be given to cyclists. This could possibly be funded by government or by a group of relevant stakeholders in Sheffield and across the UK (e.g. other local authorities and tram operators).
- Continue to investigate options to improve the rail installation – including the rail surface, groove area and adjacent surfaces, in conjunction with stakeholders and academic and commercial organisations – to try to improve the safety of cyclists crossing the rails especially at shallow angles. If viable, consider implementing a trial on-street sponsored by stakeholders in Sheffield.
- Seek further cooperation with UKTRAM, other Councils, academic bodies, cycle organisations and tramway operators concerning matters relating to cycle safety near tramways to develop best practice in this area.



## Appendix 12

### Tram Rail – Groove Fillers

### TRAM RAIL – GROOVE FILLERS

Amey Consulting  
Sheffield

Updated June 2015

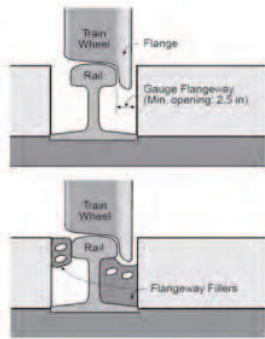


### Rail gaps – Level Crossings

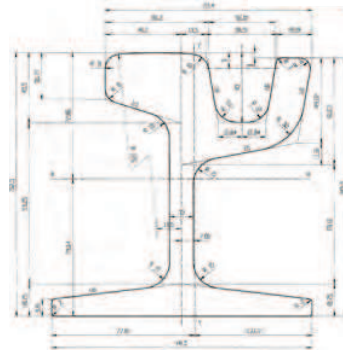
Fig. 2-39: Basic structure of a rail-road crossing.



### Flange fillers



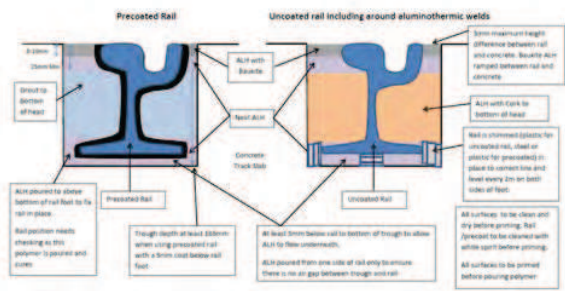
### Grooved Tram Rail



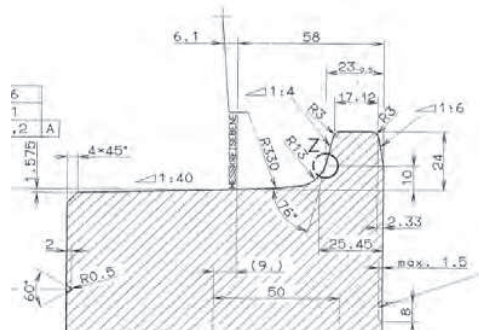
### Tram Slab Construction - Sheffield



### Grooved Tram Rail



### Sheffield Tram Wheel & Flange



### Groove Inserts - Issues

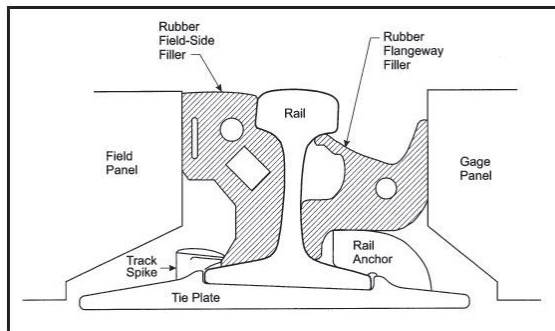


- Groove is very shallow
- Flange is quite deep
- Not much space left for compression of material

#### Also

- Will insert material return to full height after tram passage?
- Effect of temperature & freezing on compression / bounce back?
- Incompatibility with flange running?
- Risk of derailment?
- Risk of stripping out?
- Life of material?
- Cost of fitting, maintaining and replacing?

### Heavy Rail Flangeway Fillers



### USA – Cherry Avenue Bridge, Chicago



Very low frequency – heavy rail crossing

### USA – Level Crossing



Low frequency - heavy rail crossing

### Zurich Tramway - Filler Trial



Zurich Tramway – Filler trial

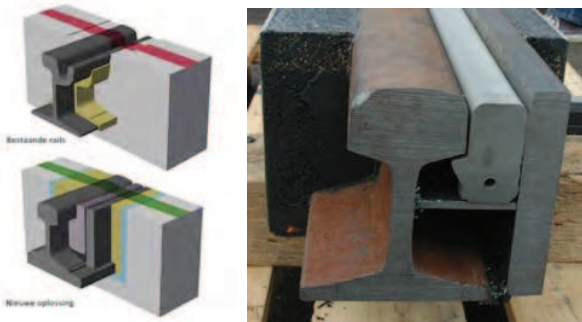


Zurich Tramway – Filler trial



Test run on the cycle-friendly tram tracks

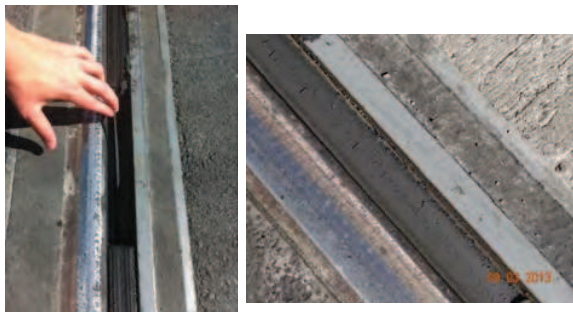
Zurich Tramway – Filler trial



Zurich filler – stripping out



Zurich filler – breaking up



Zurich filler – breaking up



Zurich Feedback

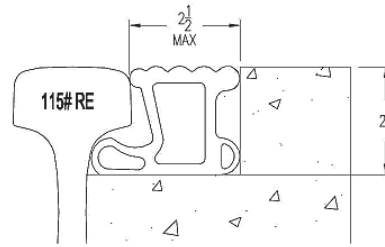


*"The participants considered the new design as being mostly much better than conventional tram tracks, with the bicycle tyres no longer being bound by the tram tracks.*

*However the risk of slipping on the rails with and without the rubber infill was felt to be about the same, even though the tyre grip on wet tram tracks with the rubber infill was better.*

*Participants in the tests could ride the new tram rails much more safely and were more relaxed as they no longer had to cross the rails at a right angle."*

Seattle – Gap Filler



Seattle gap filler – only for low frequency usage (on access route to depot)

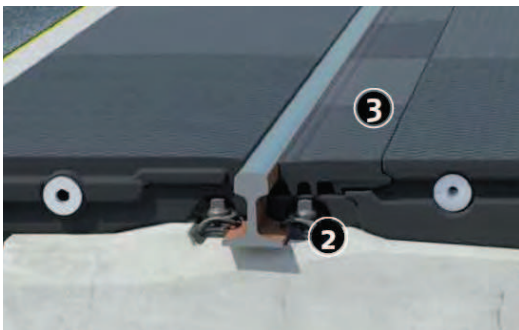
VeloStrail system



VeloStrail – Level Crossing



VeloStrail system



VeloStrail system



veloStrail – replaceable flexible insert section (honeycomb format)



Short section of veloStrail – across a cycle lane - Geneva

## Summary

- **Fillers in standard grooved rail**
  - Unlikely ever to be viable (not enough space)
- **Fillers in a gap alongside a standard rail head**
  - Might be possible with improved materials
  - No current products available that are suitable for tramway use with normal urban tram frequencies
- **VeloStrail (or similar products)**
  - Requires full area between two rails
  - More suitable for rail crossings of roads
    - Rather than linear travel along a road
  - Engineering problems to retrofit on most existing tramways
    - Not compatible with many tram slab construction methods
    - Fairly high cost of installation, maintenance and regular replacement of compressible sections